

Regulating the p53 pathway: *in vitro* hypotheses, *in vivo* veritas

Franck Toledo^{*†} and Geoffrey M. Wahl[§]

Abstract | Mutations in *TP53*, the gene that encodes the tumour suppressor p53, are found in 50% of human cancers, and increased levels of its negative regulators MDM2 and MDM4 (also known as MDMX) downregulate p53 function in many of the rest. Understanding p53 regulation remains a crucial goal to design broadly applicable anticancer strategies based on this pathway. This Review of *in vitro* studies, human tumour data and recent mouse models shows that p53 post-translational modifications have modulatory roles, and MDM2 and MDM4 have more profound roles for regulating p53. Importantly, MDM4 emerges as an independent target for drug development, as its inactivation is crucial for full p53 activation.

The transcription factor p53 responds to diverse stresses (including DNA damage, overexpressed oncogenes and various metabolic limitations) to regulate many target genes that induce cell-cycle arrest, apoptosis, senescence, DNA repair or alter metabolism^{1,2}. p53 might also induce apoptosis through non-transcriptional, cytoplasmic processes³, but such processes might require products generated by p53 transactivation⁴. In effect, p53 prevents cells from entering or progressing through the cell cycle under conditions that could generate or perpetuate DNA damage. As the inactivation or activation of p53 sets up life or death decisions, an exquisite control mechanism has evolved to prevent its errant activation at the same time as enabling rapid stress responses. Apparently central to this regulation are the opposing effects exerted by the essential p53 inhibitors MDM2 and MDM4, and transcription co-activators such as p300 (REF. 5). An increasing number of other proteins, reviewed below, are emerging as additional participants in p53 control.

The p53 pathway is crucial for effective tumour suppression in humans. Mutations in *TP53* that compromise p53 function occur in 50% of human cancers⁶, and the alteration of regulators of p53 occurs in many of the remainder. For example, the *MDM2* gene, which encodes a ubiquitin ligase, is amplified in at least 7% of all cancers without concomitant *TP53* mutation⁷. The existence of wild-type p53 in a significant fraction of human tumours has stimulated the search for a new class of agents to selectively activate it. However, detailed knowledge of the molecular mechanisms of p53 regulation will be required to develop optimal agents and treatment strategies. Here, we review data

obtained from *in vitro* studies, the human p53 mutation database, and recent mouse models to deduce p53 regulatory mechanisms. This analysis reveals a disconnect between several hypotheses generated by *in vitro* transfection studies and mouse models, which is probably explained by the ability of mouse models to preserve crucial stoichiometric relationships between p53 and its negative and positive regulators. The data show that p53 post-translational modifications have modulatory roles, and that the related proteins MDM2 and MDM4 have more profound roles in p53 regulation.

p53 regulation model based on *in vitro* studies

p53 is a modular protein with an N-terminal transactivation domain (TAD), a potential conformational element consisting of a proline-rich domain (PRD) adjacent to the TAD, a large DNA-binding domain (DBD), a tetramerization domain (4D) and a basic C-terminal domain (CTD). The primary amino-acid sequence of p53 contains many conserved serine, threonine and lysine residues that are of potential regulatory significance. Indeed, work conducted in cell-free systems and by *in vitro* transfection over the past two decades has led to the conclusion (despite some conflicting data⁸) that p53 post-translational modifications at these conserved residues have a crucial role in p53 stabilization and activation⁹. What emerges from these studies is an elegant model of p53 regulation (FIG. 1) in which DNA damage activates damage-responsive kinases to phosphorylate serines 15 and 20, which are adjacent to or within the TAD. This region comprises an important binding site for MDM2. Additional phosphorylation of threonine 18 alters the structure of the amphipathic

*Institut Curie, Centre de Recherche, UMR CNRS 7147, 26 rue d'Ulm, 75248 Paris Cedex 05, France.

†Université Pierre et Marie Curie – Paris 6, France.

§The Salk Institute for Biological Studies, Gene Expression Laboratory, 10010 North Torrey Pines Road, La Jolla, California 92037, USA.

Correspondence to F.T. and G.M.W.

e-mails: franck.toledo@curie.fr; wahl@salk.edu

doi:10.1038/nrc2012

At a glance

- *In vitro* and transfection studies have suggested a p53 regulation model that emphasizes the importance of phosphorylation to produce structural changes in p53 to enable competition between MDM2 and p300 for binding the N-terminal p53 transactivation domain and inducing competing modifications in the p53 C-terminal regulatory domain. In unstressed cells, MDM2 binding in the N terminus would inhibit p53 activity and the MDM2-mediated ubiquitylation of the C terminus would promote p53 degradation; after stress, the phosphorylation of the p53 N terminus increases p300 binding, and the p300-mediated acetylation of the C terminus stabilizes and activates p53.
- The above model is not supported by recent *in vivo* studies, because mouse mutants that express different point mutations in the N terminus and C terminus of p53 do not have the predicted phenotypes. Analysis of mutations found in human tumours also suggest that modifiable serine, threonine and lysine residues in the N-terminal and C-terminal domains do not provide on–off switches for p53.
- Recent mouse mutants confirm the importance of MDM2 in p53 regulation, and show the separate contribution of the MDM2-related protein, MDM4 (also called MDMX) for p53 regulation: *in vivo* data now indicate that MDM2 mainly regulates p53 stability, whereas MDM4 contributes significantly to regulating p53 activity. These and other data suggest that a switch from MDM2 degradation of p53 to degradation of itself and MDM4 is responsible for p53 accumulation and activation after stress.
- These results indicate the importance of developing drugs that antagonize MDM2–p53 and MDM4–p53 interactions. Candidate MDM2 antagonists have been developed, but not MDM4 antagonists.
- Importantly, MDM2 and MDM4 antagonists could cooperate to activate p53 in two to three million patients diagnosed with cancer each year.
- As p53, MDM2 and MDM4 interact with many proteins, further analyses of these interactions might also lead to new and broadly useful anticancer strategies.

Prolyl isomerase

An enzyme that catalyses the cis-trans interconversion of prolines in specific amino-acid motifs. For example, PIN1 binds to motifs containing a phosphorylated serine or threonine preceding a proline, and catalyses the isomerization of the proline residue.

Sumoylation

Conjugation with a small ubiquitin-like modifier protein (SUMO) of one or several lysines within the protein, which might regulate protein function. The 3D structure of SUMO1 is very similar to that of ubiquitin, although they share only 18% amino-acid sequence identity.

Neddylation

Conjugation with NEDD8 (neural precursor cell expressed developmentally downregulated 8) of one or several lysines within the protein, which might regulate protein function. NEDD8 is an 81 amino-acid protein that shares 60% amino-acid sequence identity with ubiquitin.

α -helix with which MDM2 interacts, and the phosphorylation of threonine–proline motif(s) enables the binding of the prolyl isomerase **PIN1** to induce cis-trans prolyl isomerizations within the PRD. Together, these modifications and associated conformational changes are proposed to reduce the affinity of p53 for MDM2, and to enable tighter association with co-activators, such as the histone acetyl transferases (HATs) p300 and CREB-binding protein (**CBP**) (FIG. 1). Although p53 is unstable and ubiquitylated at C-terminal lysines by MDM2 in unperturbed cells, stresses like DNA damage stabilize p53 through acetylation at these lysines by HATs such as p300 (FIG. 1).

Importantly however, this model integrates only a fraction of the possible post-translational modifications of p53 (FIG. 2a). Many of these modifications were recently reviewed in this journal¹⁰. Below, we briefly summarize these data and discuss additional data acquired in the past 2 years that indicate the need to consider an alternative regulatory model.

Phosphorylation of serines and threonines. Human p53 has 23 different phosphorylation and dephosphorylation sites (FIG. 2a). The regulation of p53 function by phosphorylation and dephosphorylation could, therefore, occur through many sites, most of which are outside the DBD. Most residues are phosphorylated by many different kinases in response to many stresses and are associated with p53 activation¹⁰. This defines two levels of potential redundancy, as a specific residue can be phosphorylated by several kinases (for example,

serine 15 is phosphorylated by at least 8 kinases), and a specific kinase can phosphorylate several residues (for example, **CHK2** phosphorylates 7 different residues). Such redundancy might provide a fail-safe mechanism to enable diverse stresses to activate p53 (REF. 10). As some residues seem to be phosphorylated by a single kinase, unique phosphorylation patterns might determine a subset of cellular responses. Alternatively, this could reflect incomplete knowledge of the relevant kinases and their targets. For example, serine 378 was thought to be phosphorylated by a single kinase just 2 years ago¹⁰, but recent data indicate that three different kinases are involved¹¹. Additionally, the dephosphorylation of some residues has been correlated with activation; therefore serine 376 is phosphorylated in unstressed cells and dephosphorylated after ionizing irradiation, correlating with the interaction of p53 with 14-3-3 proteins¹². Conversely, the phosphorylation of serine 215 by **Aurora kinase A** reportedly inhibits the binding of p53 to DNA and overrides stress responses induced by cisplatin and γ -irradiation¹³.

Lysine modification. p53 C-terminal lysines are modified by ubiquitylation, acetylation, sumoylation, neddylation and methylation (FIG. 2a). Neddylation seems to inhibit transactivation, whereas sumoylation can positively or negatively affect p53 function¹⁰. Recently, p53 sumoylation was proposed to induce senescence in normal human fibroblasts but apoptosis in **RB** (retinoblastoma 1)-deficient cells¹⁴. Modifications of lysine 320 were proposed to promote cell-cycle arrest, rather than apoptosis^{15–17}. Unlike lysines 372, 373, 381 and 382, which are acetylated by p300 and ubiquitylated by MDM2 (REF. 10), lysine 320 is acetylated by the p300 and CBP associated factor (**PCAF**)^{15,16,18} and ubiquitylated by **E4F1** (REF. 17). The E4F1-mediated lysine 48-like oligo-ubiquitylation has been proposed to induce cell-cycle arrest rather than promote p53 degradation¹⁷. Methylation at nearby lysines might also have dramatically different effects: lysine 372 methylation by **SET9** stabilizes p53 (REF. 19), whereas the methylation of lysine 370 by **SMYD2** destabilizes it (S. Berger, personal communication).

One interpretation of the increasing variety and complexity of p53 modifications at serines, threonines and lysines (FIG. 2a) is that the elegant model of p53 regulation in FIG. 1 is oversimplified. The rigorous testing of the functional affect of several p53 modifications using targeted mutations at the mouse *Tp53* locus further challenges the validity of this model, and brings up an alternative view in which p53 regulation depends less on its post-translational modifications and more on the control of MDM2 and MDM4.

In vivo data challenge the in vitro model

Mouse mutants of putative regulatory sites have unexpected phenotypes. The *in vitro* studies have been very valuable in that they have enabled the formulation of a model that makes strong predictions about which residues in p53 should be involved in its regulation, as well as the phenotypic effects of changing these

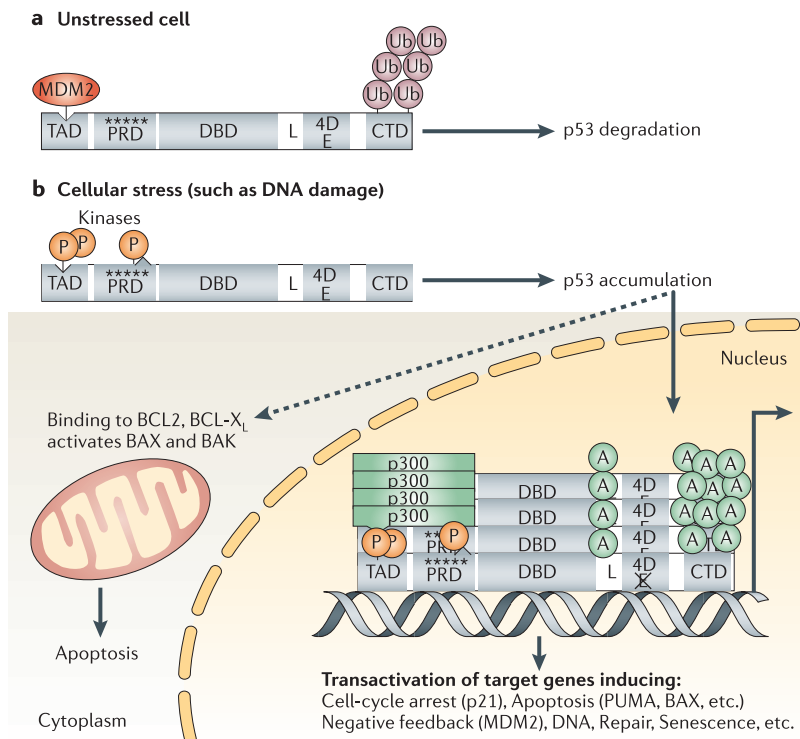

Figure 1 | A model for p53 regulation based on *in vitro* and transfection data. **a** | p53 regulation in unstressed cells. Human p53 consists of 393 amino acids, with 5 proposed domains. The transactivation domain (TAD; amino-acid residues 1–40), required for transcriptional activation. The proline-rich domain (PRD; residues 61–94), containing 5 PXXP motifs (where P is a proline and X any other residue; asterisks) that enable protein–protein interactions¹⁰³. This domain is thought to participate in the regulation of p53 stability and activity (this domain partially overlaps residues 43–73, previously defined as a weaker secondary TAD¹⁰⁴). The DNA-binding domain (DBD; residues 100–300) specifically binds to DNA consensus recognition elements in the promoters of target genes. The tetramerization domain (4D; residues 324–355). And the C-terminal regulatory domain (CTD; residues 360–393) that binds DNA nonspecifically and might regulate specific DNA binding by the DBD^{105,106}. Also noteworthy are a nuclear localization signal (L) located between the DBD and the 4D, and a nuclear export signal (E) embedded in the 4D¹⁰⁷. In unstressed cells, p53 is kept inactive and at low levels essentially because of the action of MDM2, which inhibits p53 in two main ways: it quenches p53 transcriptional activity by occluding the p53 TAD (thereby preventing p53 from recruiting transcriptional co-activators such as p300)¹⁰⁸ and, through its ubiquitin-ligase activity, can ubiquitylate lysines in the p53 CTD to promote p53 degradation by the proteasome¹⁰⁹. **b** | p53 stabilization and activation after stress. After various cellular stresses, stress-induced kinases phosphorylate p53. The phosphorylation of serines and threonines in the TAD (serine 15, threonine 18 and serine 20) reduces the binding of MDM2 (REF. 110). Modifications in the PRD can also participate in reduced MDM2 binding: the stress-induced phosphorylation of threonine 81 in the PRD creates a binding site for the prolyl isomerase PIN1 and the consecutive isomerization of proline 82 disfavours MDM2 binding³⁸. Reduced MDM2 binding leads to p53 accumulation, to form tetramers. Importantly, tetramerization masks the nuclear export signal, so that accumulated p53 tends to remain in the nucleus¹⁰⁷ (in addition, stress-induced phosphorylation of the p53 TAD presumably conceals another proposed nuclear export signal¹¹¹). The phosphorylation of the p53 TAD favours the interaction with histone acetyl transferases such as p300 (REF. 112), which bind the PRD through PXXP motifs³⁹. This leads to the acetylation of lysines in the p53 CTD to promote p53 stabilization and increase specific DNA binding at target genes⁵. p300 can also acetylate histones at the promoters of target genes, therefore inducing promoter opening and enabling transcription activation¹¹³ to induce different cellular responses¹². Among the induced target genes is MDM2, so its transactivation creates a negative-feedback loop. Although accumulated p53 is preferentially located in the nucleus, some studies suggest that following stress, a fraction of the p53 molecules could remain in the cytoplasm to bind anti-apoptotic BCL2 or BCL-X_L and promote apoptosis through mitochondrial outer membrane permeabilization³⁴. A, acetylated lysines; P, phosphorylated serines and threonines; Ub, ubiquitylated lysines.

residues in specific ways. The advent of homologous recombination in the mouse has enabled this p53 regulation model to be tested *in vivo*. In most cases, mutant mice were produced and the phenotypes were studied in whole animals and/or in primary mouse embryonic fibroblasts (MEFs) or thymocytes derived from them. The strength of this approach is that mutant p53 proteins are expressed from the endogenous promoter, ensuring physiological expression levels and correct spatio-temporal regulation.

The first targeted mutation tested the importance of the N-terminal p53 TAD for interaction with MDM2, and for HAT recruitment to enable chromatin binding and transactivation^{20,21}. Transfection studies showed that mutating leucine 22 and tryptophan 23 of human p53 into glutamine and serine (L22Q and W23S, referred to as p53^{QS}) prevented MDM2 interaction and severely reduced target-gene transactivation²². A mouse mutant with the equivalent changes (L25Q and W26S) was made by three different groups^{20,21,23} (FIG. 2b). Despite differences recently discussed elsewhere²⁴, these studies generated similar data showing that p53^{QS} is very stable owing to decreased MDM2 binding. Consistent with a failure to recruit HATs, DNA damage did not induce acetylation on C-terminal lysines²¹, and p53^{QS} failed to induce the transcription of most p53 target genes after DNA damage. Therefore, the *in vivo* analyses of p53^{QS} are largely consistent with *in vitro* studies. However, p53^{QS} has early embryonic lethality, possibly due to a residual transcription function activated by stresses associated with embryogenesis²³, although other possibilities have not been excluded²⁵. Importantly, p53^{QS} binds tightly to chromatin²⁴, showing that HAT recruitment and p53 C-terminal acetylation are not required for p53 to bind to chromatin.

In striking contrast, targeted mutations of serines in the TAD, and lysines in the CTD, generated data that are inconsistent with *in vitro* analyses and the model shown in FIG. 1. The phosphorylation of serines and threonines in the TAD were predicted to be crucial for stabilizing and activating p53 by preventing MDM2 binding and promoting p300 binding. This derives from the proximity of these modifications to residues 22 and 23, which the studies above showed to be so crucial for p53 stability and function, and because serines 15 and 20 are close to or within the α -helix formed by p53 residues 18–26 that binds MDM2. It was surprising when the mutation of S18A in mouse p53 (equivalent to a S15A mutation in human p53) led to a modest phenotype^{26,27} that had normal p53 stability in unstressed and DNA-damaged cells, normal cell-cycle control, cell-type-specific partial defects in apoptosis and normal tumour suppression (TABLE 1). The targeted mutation T23A in the mouse (equivalent to human S20A) also led to a subtle phenotype^{28,29} (TABLE 1), with one study reporting a partial defect in p53 accumulation and apoptosis in irradiated thymocytes²⁹. Mutant mice developed B-cell lymphomas, but with a long period of latency (around 18 months, compared with 6–10 months in *Trp53*^{-/-} mice). Recently, a targeted double mutation (S18A and S23A, called p53^{S18,23A}) was

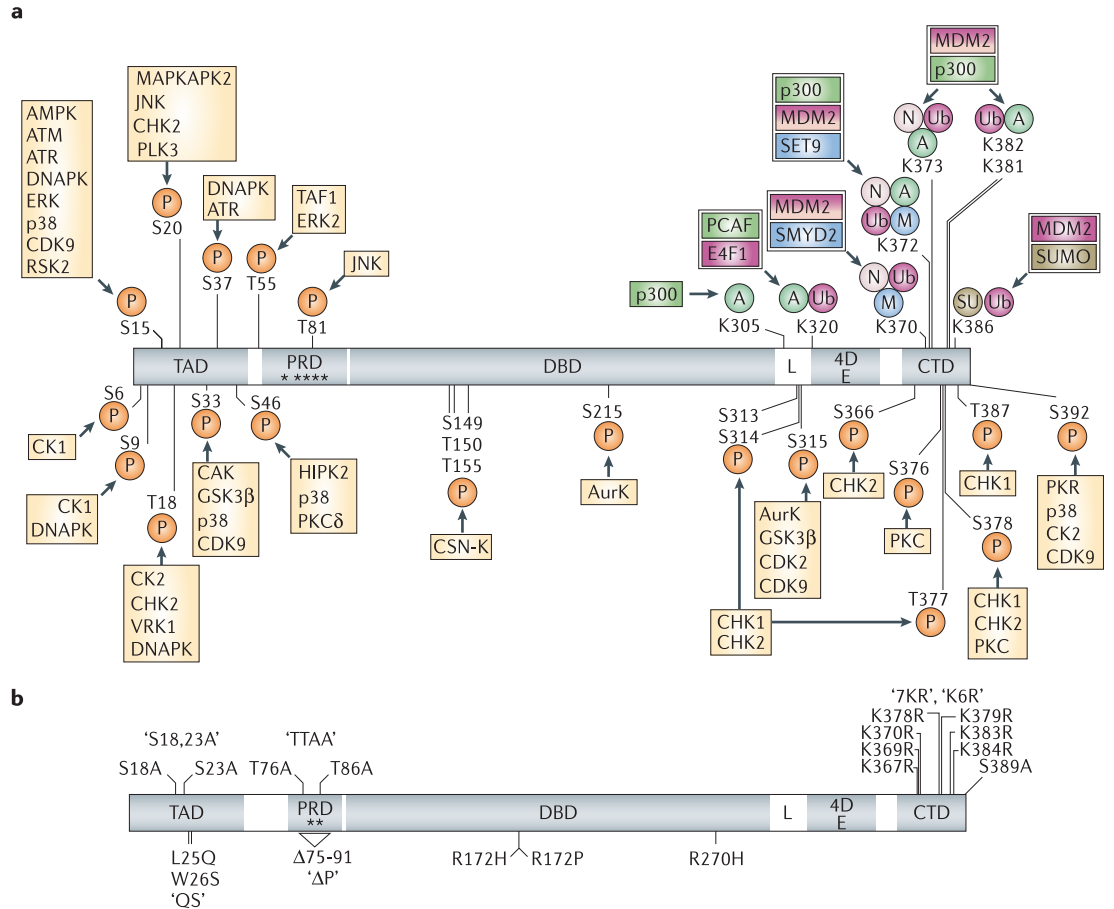

Figure 2 | Comparative maps from *in vitro* human p53 and *in vivo* mouse p53 studies. a | Post-translational modifications of human p53. Specific residues are modified as shown, with phosphorylation (P) in orange, acetylation (A) in green, ubiquitylation (Ub) in purple, neddylation (N) in pink, methylation (M) in blue and sumoylation (SU) in brown. Proteins responsible for these modifications are shown in matching colours. **b** | Targeted mutations at the mouse p53 locus. Mouse p53 shares a strong homology with human p53, but a few differences can be noted, including: mouse p53 is comprised of 390 amino acids; the N-terminal part of mouse p53 is longer by 3 residues, so that the numbering is higher in the murine transactivation domain (TAD) than in the human TAD; the p53 proline-rich domain (PRD) is loosely conserved in evolution (the murine PRD is shorter, and contains 2 PXXPs motifs and 2 putative PIN1 sites instead of 5 PXXPs and 1 PIN1 site in the human PRD); in the DNA-binding domain and the C-terminal part of the protein, numbering is lower by 3 amino acids in murine compared with human (mouse serine 389 is functionally equivalent to human serine 392); the C-terminal regulatory domain (CTD) of mouse p53 contains 7 lysines, instead of the 6 in human p53. Residues that are subject to stress-induced modifications and that have been targeted at the mouse p53 locus are shown. Below the protein are shown other targeted mutations which provided valuable information on p53 function, but did not precisely target residues modified by stress. For several point mutations, abbreviated names are mentioned (for example, QS instead of L25Q,W26S). AMPK, adenosine monophosphate-activated protein kinase; ATM, ataxia telangiectasia mutated; ATR, ataxia telangiectasia and Rad3-related protein; AurK, Aurora kinase A; CAK, CDK-activating kinase; CDK, cyclin-dependent kinase; CHK, checkpoint kinase; CK, casein kinase; CSNK, cop-9 signalosome associated kinase complex; DNAPK, DNA-dependent protein kinase; ERK, extracellular signal-regulated kinase; GSK3β, glycogen synthase kinase 3β; HIPK2, homeodomain-interacting protein kinase 2; JNK, c-Jun NH₂-terminal kinase; MAPKAPK2, mitogen-activated protein kinase-activated protein kinase 2; p38, p38 kinase; PCAF, p300/CBP associated factor; PKC, protein kinase C; PKR, double stranded RNA-activated kinase; PLK3, pol-like kinase 3; RSK2, ribosomal S6 kinase 2; SET9, SET9 methyltransferase; SMDY2, SET/MYND domain-containing methyltransferase 2; SUMO, small ubiquitin-like modifier 1; TAF1, TATA-binding protein-associated factor 1; VRK1, vaccinia-related kinase 1.

analysed *in vivo*³⁰: p53^{S18,23A} has modest defects in cell-cycle control and the induction of cellular senescence and seems to be unable to induce apoptosis, which might explain the ability of homozygotes to rescue embryos deficient in the DNA-repair protein *XRCC4* (REF. 30) (however, this assay is not very stringent because *Trp53*^{+/-} animals can rescue *Xrcc4*

deficiency, albeit with reduced efficiency³¹). These results indicate a functional synergy between serine 18 and serine 23 for at least some p53 functions such as apoptosis, but importantly, the combined mutation of both residues still fails to abolish all p53 functions and only marginally alters protein stability, which contrasts with data obtained by transfection analyses.

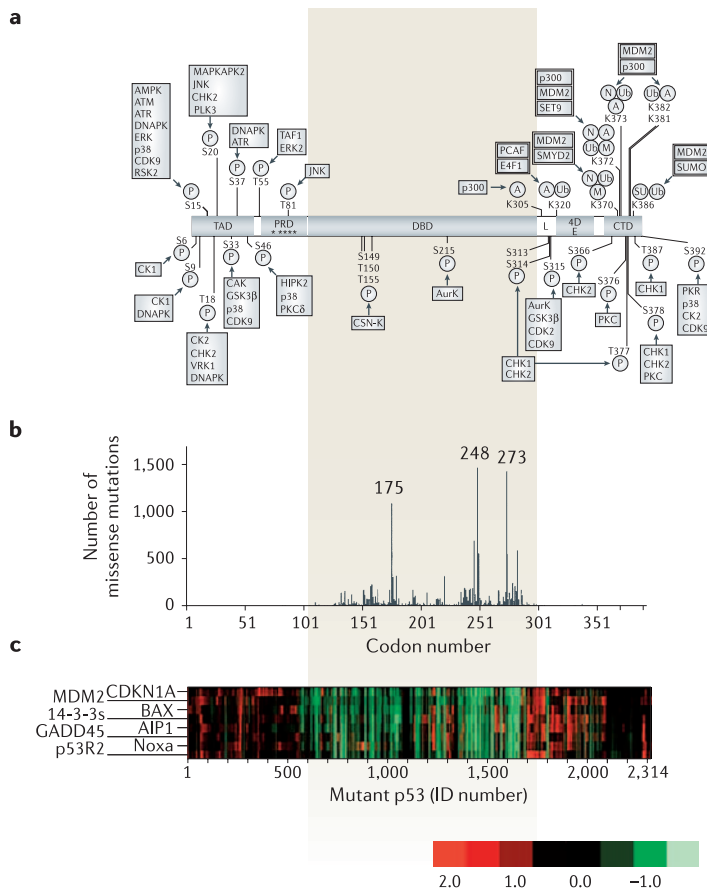

Figure 3 | The distribution of codons mutated in human tumours and their effect on p53 transcriptional activity. **a** | Map of human p53. Modified residues are indicated. For details on modifications, see Figure 2a. **b** | The distribution of missense mutations in human tumours. The number of missense mutations in human tumours for each codon, according to the International Agency for Research on Cancer (IARC) *TP53* mutation database R10 (July 2005), was plotted against the p53 map. Data are from a total of 15,911 tumours. The three most frequently affected codons (mutated >1,000 times) are indicated. **c** | Transcriptional activity of missense mutants assayed in yeast. The transactivation activity of 2,314 missense human p53 mutants was assayed in yeast: their capacity to transactivate 8 p53 target genes (*CDKN1A*, *MDM2*, *BAX*, 14-3-3 σ , *AIP1*, *GADD45*, *Noxa*, *p53R2*), relative to that of wild-type p53, is plotted against the map. For more details, see REF. 52, from which this figure is reproduced. The grey zone across the top and bottom indicates the residues 100–300 that constitute the DNA-binding domain.

Data from *in vitro* studies generated the strong prediction that the p53 CTD should be a regulatory nexus in which degradation signals generated by lysine ubiquitylation would compete with stabilizing and activating signals generated by acetylation and other modifications of the same residues^{5,32,33}. However, mouse mutants that expressed p53 in which the C-terminal 7 (REF. 34) or 6 (REF. 35) lysines were mutated to arginine residues (referred to as p53^{7KR} or p53^{6GR}, respectively) were surprisingly similar to mice with wild-type p53. Therefore, p53^{7KR/7KR} mice were viable and seemed phenotypically normal, p53^{7KR} had normal stability, and MEFs showed normal cell-cycle arrest. Furthermore, MEFs and thymocytes elicited normal apoptotic responses, and p53^{7KR/7KR} MEFs that expressed both E1A and Ras failed to generate tumours in nude mice³⁴. However,

unlike wild-type MEFs, p53^{7KR/7KR} MEFs were resistant to spontaneous immortalization after extended serial passaging, and p53^{7KR} was activated more efficiently than wild-type p53 in irradiated thymocytes³⁴. These results suggested that lysines in the CTD are not essential for p53 function, but instead fine-tune stress responses³⁴. Some differences were noted between the p53^{6GR} and p53^{7KR} mutants, but it is unclear whether they result from the additional K384R mutation in p53^{7KR}, or because blastocyst complementation rather than a standard breeding approach was used in the p53^{6GR} study³⁵. Nevertheless, the normal stability and apoptotic responses of p53^{6GR} are also consistent with the idea that lysines in the p53 CTD are not essential for p53 function³⁴. These data question the importance of CTD ubiquitylation and acetylation for p53 regulation (FIG. 1), and challenge the functional affect of other CTD modifications such as neddylation, methylation and sumoylation (FIG. 2a).

The PRD has also been proposed to have important roles in p53 stabilization and activation on the basis of *in vitro* analyses (FIG. 1). Evidence that the PRD influences p53 stabilization first came from studies that showed that human p53 with a deletion of residues 62–91 in the PRD (a mutant commonly called p53^{AP}) had increased sensitivity to MDM2-mediated degradation^{36,37}, which might derive from the removal of a crucial binding site to the prolyl isomerase PIN1 (REF. 38). Although several PIN1 sites exist in human p53, the PIN1 site in the PRD (threonine 81–proline 82) seems to be essential because proline 82 is isomerized by PIN1, enabling the recruitment of CHK2 to phosphorylate serine 20 and consequently reduce MDM2 binding³⁸. The PRD might also ensure optimal p53–p300 interactions through PXXX motifs³⁹. We addressed the role of the p53 PRD *in vivo* by targeting the deletion of this domain at the mouse *Tp53* locus⁴⁰. The p53 PRD is loosely conserved in evolution (FIG. 2a,b), and the targeted deletion was based on data that showed the similar properties elicited after the transfection of the corresponding p53^{AP} mouse and human mutants⁴¹. The targeted deletion of amino acids 75–91 removed all PXXX motifs and putative PIN1 sites in the murine p53 PRD (FIG. 2b). Consistent with *in vitro* studies, mouse p53^{AP} displayed increased MDM2-mediated degradation and decreased transactivation capacity⁴⁰. We recently generated another mouse strain in which threonines 76 and 86 were mutated to alanines (that is, p53^{T76A/T86A}) to remove the putative PIN1 sites in the PRD to ascertain whether the defects in p53^{AP} specifically derive from an inability to undergo PIN1-mediated PRD isomerization. p53^{T76A/T86A} accumulation after DNA damage is partially compromised, but it transactivates target genes and suppresses oncogene-induced tumours similar to wild-type p53 (F. T. and G.M.W., unpublished observations). These results indicate that PIN1 sites in the PRD participate in p53 stability control, but they have little effect on p53 function. Therefore, the targeted point mutation generated a more modest phenotype than predicted by the *in vitro* data.

Analysis of the PRD showed the unexpected result that the mouse p53^{AP} mutant failed to undergo cell-cycle arrest but was competent for apoptosis induction

Table 1 | Mice that express p53 with targeted mutations of modified residues have modest phenotypes

Mutations of modified residues	Expected phenotype	Observed phenotype
S18A	Increased or constitutive MDM2 binding; impaired p53 accumulation and transactivation capacity; deficient cell-cycle arrest and apoptosis responses; poor tumour suppression	No alteration in p53 stability; mild transactivation defect; normal cell-cycle arrest response and only a mild apoptosis defect; efficient tumour suppression
S23A	See S18A	No or mild alteration in p53 stability; no transactivation defect; normal cell-cycle control and mild apoptosis defect; mice develop B-cell lymphomas with a long latency (>1 year)
S18,23A	See S18A	Mild alteration in p53 stability; mild transactivation defect (similar to S18A); partial cell-cycle control but little pro-apoptotic capacity; mice develop a wide spectrum of tumours after a long latency (>1 year)
TTAA	See S18A	Mild alteration in p53 stability; no transactivation defect; normal cell-cycle control and apoptosis; efficient suppression of oncogene-induced tumours
7KR	Dramatic increase in p53 stability and activity	No alteration in p53 stability; normal cell-cycle control and apoptosis; very mild increase in p53 activity observed in only a subset of conditions
K6R	See 7KR	No alteration in p53 stability; normal apoptosis; decrease in the transactivation of a subset of target genes
S389A	Effect on DNA binding and transactivation in response to UV but not γ -irradiation	No effect on p53 stability; mild effect on transactivation and apoptosis in response to UV but not γ -irradiation; mice are not prone to spontaneous tumours but have a moderate predisposition to UV-induced skin tumours

at a reduced efficiency⁴⁰, which is the opposite of what most *in vitro* studies found^{41–47}. Importantly, transfection studies with the p53^{Δp} mutant^{36,37} showed that its activity was exquisitely sensitive to MDM2 abundance. Similar observations were made *in vivo* by changing *MDM2* gene dosage⁴⁰. This suggests that difficulties in accurately reproducing stoichiometric relationships between members of the p53 network owing to the use of transfection probably contributes to discrepancies between *in vitro* and *in vivo* data.

Serine 392 is one of the most highly conserved residues in human p53, and is a target of several kinases. *In vitro* studies indicate that it is selectively responsive to UV light^{48,49}. Mice with the equivalent mutation (S389A) had normal regulation of p53 stability but a slightly reduced apoptotic response after UV irradiation. Importantly, p53^{S389A/S389A} mice were not prone to spontaneous tumorigenesis, but showed a slight predisposition to UVB-induced skin tumours⁵⁰. Therefore, the mutation of this kinase target site again had very modest phenotypic consequences. Altogether, the data from mouse mutants (TABLE 1) suggest that the conservation of modifiable residues (and of their stress-induced modifications) is not enough to create the on–off switches proposed by the classical model of p53 regulation (FIG. 1).

Inferences on p53 structure–function relationships derived from the human p53 mutation database. One interpretation of the significant differences between the *in vitro* and *in vivo* analyses reviewed above could be that there are differences in regulatory strategies between humans and mice, as the *in vitro* and transfection studies largely used human cells and human transfected genes. However, we do not favour this interpretation because, as detailed below, the analysis of the

data in the human p53 mutation database supports the modest phenotypes caused by single or several serine, threonine and lysine mutations in mouse p53. Indeed, if a mutation such as S15A in human p53 (or S18A in mouse p53) strongly and negatively affected p53 function, one would expect it to be frequently selected during tumour formation, and consequently often be seen in tumour biopsies.

We investigated this idea by determining the frequency of mutations in all serine, threonine, and lysine residues using the tenth release of the International Agency for Research on Cancer (IARC) *TP53* mutation database⁵¹, which contains 21,587 somatic mutations. From 15,911 missense mutations (FIG. 3b), only six were found for all serines and threonines in the TAD, threonine 81 in the PRD was mutated only twice, and five mutations were found for all serines, threonines and lysines in the CTD. This distribution is consistent with the conclusion from mutant mouse models that the mutation of a single residue in the TAD, the PRD or the CTD should elicit small phenotypic effects. Also consistent with this conclusion, when the transactivation capacity of 2,314 human p53 missense mutants was systematically tested in yeast expression assays⁵², mutations in the TAD, the PRD and the CTD seemed to only marginally affect transactivation (FIG. 3c). By contrast, mutations in the DBD are frequently found in human tumours (FIG. 3b), and most mutations in the DBD dramatically affected transactivation efficiency in yeast assays (FIG. 3c). These results again agree with data from mouse models: targeted mutations R172H and R270H in the mouse (corresponding to the R175H and R273H mutations common in human tumours) dramatically affected mouse p53 functions, and acquired oncogenic properties that promoted metastasis^{53–55}. Furthermore, arginine 175 was found

to be mutated in 1,030 human tumours, with the most frequent mutation being R175H (941 cases). By contrast, the R175P mutation is rare (7 cases). Such differences result in part from the distinct events required to mutate an arginine into either residue, but the p53^{R172P} mouse mutant also suggests that this mutation is not frequently selected during tumour evolution because unlike the oncogenic p53^{R172H}, p53^{R172P} retains some tumour-suppressor capacity⁵⁶.

These data from mouse models, human tumours and expression analyses in yeast are remarkably consistent, and suggest that the mutation of a single residue from the TAD, PRD or the CTD, even if it is modified by phosphorylation, ubiquitylation, acetylation, neddylation, sumoylation or methylation, is likely to preserve sufficient p53 function as to not engender a selective advantage. The combined mutation of several modified residues could cause a more pronounced effect (for example, the p53^{S18,23A} mouse mutant), but then again, perhaps not (for example, the p53^{7KR} mouse mutant). However, multiple mutations should occur very rarely in spontaneous tumours, so that the mutation of a single residue in the DBD, which has much more profound (deleterious or oncogenic) effects, is expected to occur more frequently. Importantly, the fact that data from mouse models, human tumours and yeast-based expression assays are consistent suggests that the discrepancies between data from mouse models and studies of transfected human p53 mutants cannot simply be ascribed to interspecies differences in p53 regulation.

Comparisons of mouse-targeted mutations, human tumours and yeast expression assays raise two other points. First, because the distribution of mutations in human tumours seems to be consistent with transactivation deficiencies in yeast-based expression assays, one might wonder about the proposed role of cytoplasmic p53 in transcription-independent apoptosis^{3,4} (FIG. 1). Recently, 179 of the 2,314 human p53 missense mutants (from FIG. 3c) were analysed for their capacity to transactivate target genes and to induce apoptosis in Saos-2 cells⁵⁷. This analysis led to the proposal that there is no correlation between transcriptional activity and apoptosis induction⁵⁷. Importantly however, such a proposal is difficult to reconcile with the fact that all mutants able to induce apoptosis seemed to transactivate PUMA quite efficiently, if not more efficiently than wild-type p53 (REF. 57). In addition, none of the mouse models described above was shown to induce apoptosis without being able to transactivate at least one pro-apoptotic p53 target gene. Together, the present data suggest that if cytoplasmic p53 has a role in apoptosis, it still requires at least some p53 transactivation capacity, as proposed elsewhere⁴. Second, despite rather subtle phenotypes, mouse mutants p53^{S23A} and p53^{S389A} seem prone to develop late onset B-cell lymphomas and UV-induced skin cancers, respectively^{29,50}. One could wonder if the equivalent residues in human p53 are mutated only in a fraction of these tumour sites, so that their mutation frequency is underestimated by a general statistical analysis. However, no missense mutation at

either serine 20 or 392 is reported in the IARC database. Whether this reflects a difference between mouse and human tumorigenesis, or an under-representation of the relevant cancer sites in the IARC database, deserves further investigation.

Together, the *in vivo* data show significant discrepancies with *in vitro* and transfection approaches to study the p53 pathway. Several factors might account for this. First, as discussed above, it is difficult to faithfully reproduce the relative ratios of p53 and its regulators using transfection protocols, despite the attempts to express the relevant proteins at physiological levels. Second, transfection procedures can induce cellular stress, thereby activating the p53 pathway⁵⁸. Third, the recipient cells used in transfections are typically tumour cells with altered levels of p53 or its regulators^{59,60}, and with undefined aberrations in signal transduction pathways that might affect p53 activation or output. Fourth, as transfections typically use p53 cDNAs, they do not integrate the potential importance of p53 isoforms⁶¹. Importantly, all of these potential problems are resolved by analysing MEFs and other cell types that express p53 mutants generated from targeted genomic mutations. In addition, p53 functions *in vivo* in the context of cells growing in three-dimensions and in the presence of far lower oxygen tensions than used in most *in vitro* studies. Also, recent studies point to the importance of p53 in metabolic regulation, which could be affected by *in vitro* conditions (see REF. 2 for review). Clearly, then, as p53 occupies such an important stress, damage and metabolite-responsive regulatory node, *in vivo* studies are crucial for analysing the p53 pathway.

Taken together, the present data suggest that although transfection experiments with p53 modification mutants can exaggerate phenotypes, they have been valuable in identifying residues that, when modified, can modulate p53 function. However, elucidation of the functional affect of candidate residues clearly requires further analyses using *in vivo* experiments. Importantly, the possibility remains that further analyses of mice that express p53 with the mutations described here, and others still to be made, will show phenotypic consequences, perhaps restricted to particular tissues and that manifest under specific stresses, that have not been tested so far. The available data also indicate that a simple model proposing that p53 modifications function as on-off switches (FIG. 1) is probably incorrect. Rather, the conservation of many modified residues, and the subtle but significant defects caused by their mutation *in vivo*, suggest a more sophisticated model in which combinations of p53 modifications (FIG. 2a) define a 'p53 code', analogous to the proposed 'histone code' defined by histone tail modifications⁶², to enable the precise and appropriate tuning of p53 responses.

MDM2, MDM4 and mouse models

If p53 modifications enable fine tuning, it is reasonable to ask what factors convert p53 from an off to an on state in response to DNA damage and other stresses. In contrast to the modest effects of most mouse mutations that prevent p53 post-translational modifications,

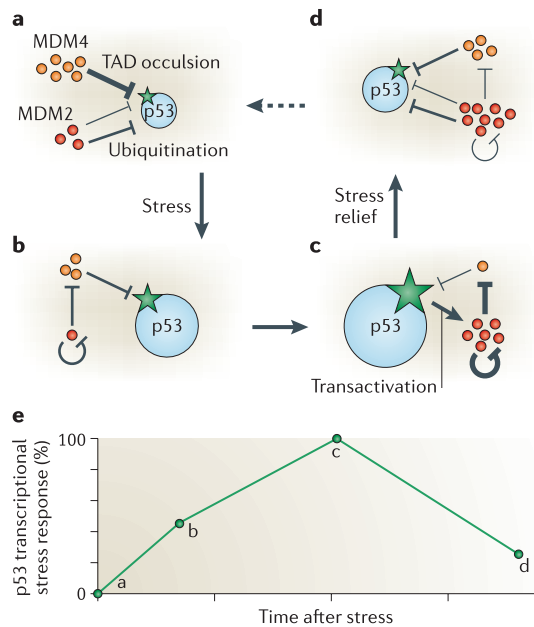

Figure 4 | p53 regulation by MDM2 and MDM4: a dynamic model of the p53 response. **a** | p53 regulation in an unstressed cell. In an unstressed cell, p53 is kept at low levels owing to MDM2-mediated ubiquitination, and inactive primarily due to MDM4-mediated transactivation domain (TAD) occlusion. In this diagram, p53 stability is represented by a blue circle, and p53 activity by a green star. MDM2 and MDM4 levels are represented by the red and orange circles, respectively. **b** | After stress, MDM2 degrades itself and MDM4, leading to the accumulation and activation of p53: a transcriptional response is mounting. **c** | As activated p53 transactivates MDM2, the increasingly abundant MDM2 degrades MDM4 more efficiently, enabling full p53 activation: the transcriptional stress response is at its peak. **d** | Following stress relief, the accumulated MDM2 preferentially targets p53 again: p53 levels decrease, and as MDM4 levels increase, p53 activity also decreases; the transcriptional stress response is fading. This might enable cell-cycle re-entry (dashed arrow). The switch that makes MDM2 preferentially target p53 for degradation in unstressed cells (**a**), then target itself and MDM4 after stress (**b** and **c**), and target p53 again after stress relief (**d**) is not precisely understood, but some of the events involved in this switch are discussed in the text. **e** | Diagram of the p53 transcriptional response. The response, a product of p53 accumulation by p53 activation, is represented at the indicated timepoints (**a–d**). Adapted from REF. 40 © (2006) Cell Press.

mouse models establish MDM2 and MDM4 as essential p53 regulators. Consistent with *in vitro* data, MDM2 is clearly a crucial negative regulator of p53 *in vivo*, as the embryonic lethality generated by its deletion is fully rescued by p53 loss^{63,64}. However, in the classical p53 regulation model, MDM4 did not have a prominent role (FIG. 1). MDM4 was identified as a p53-binding protein that was related to MDM2, but lacked ubiquitin-ligase function^{65,66}. Also unlike MDM2, transcription of the *MDM4* gene is not induced after DNA damage, and its promoter apparently lacks p53 responsive elements⁶⁷.

Importantly, MDM4 inhibits p53 transactivation in overexpression studies⁶⁵. Similar to MDM2, MDM4 can bind to the p53 transactivation domain, and experimental evidence indicates that it inhibits p53 transactivation by limiting access to essential transcriptional co-activators, and, presumably, to the basal transcription machinery⁶⁷. MDM4 can also form heterodimers with MDM2, and this association was proposed to regulate p53–MDM2 interactions. In support of this, MDM4 overexpression seemed to inhibit the MDM2-mediated degradation of p53 (REFS 66,68). Nevertheless, *in vivo* studies showed that MDM4 is also an essential p53 inhibitor: similar to MDM2, MDM4 deficiency causes early embryonic lethality rescued by p53 loss^{69–71}. An important implication of these early *in vivo* studies is that MDM2 and MDM4 are non-redundant p53 inhibitors, as each regulator is normally unable to compensate for the loss of the other.

These observations beg the question: what are the non-redundant roles that MDM2 and MDM4 have in p53 regulation? Several hypotheses have been proposed, and mouse models and *in vitro* analyses are now giving valuable clues. MDM2-null and MDM4-null embryos die at different times and from different causes. MDM2 deficiency causes early death due to increased apoptosis^{63,64} that is partially rescued by the loss of *BAX*, a pro-apoptotic p53 target gene⁷². By contrast, MDM4 deficiency causes death later, and probably because of cell proliferation arrest^{69–71} that is partially rescued by the loss of cyclin-dependent kinase inhibitor 1A (*Cdkn1a*, the gene that encodes p21), a p53 target gene that regulates proliferation⁷³. These differences led to the proposal that MDM2 and MDM4 regulate non-overlapping functions of p53, with MDM2 regulating apoptosis and MDM4 regulating cell proliferation⁶⁹. However, MDM4 was later shown to regulate apoptosis in some tissues *in vivo*^{70,71,74}. Another hypothesis, derived from transfection analyses, is that MDM4 stabilizes MDM2, whereas MDM2 enables the nuclear import of MDM4 (REF. 75), although later studies testing this model did not support it^{60,76}.

Recent mouse models provide evidence against these hypotheses and support an alternative in which MDM2 mainly controls p53 stability, whereas MDM4 functions as an important p53 transcriptional antagonist. The ability of the hypomorphic p53^{ΔP} allele to rescue MDM4, but not MDM2 deficiency enabled analyses of the consequences of MDM4 loss on p53 and MDM2 function⁴⁰. MDM2 stability was not affected by loss of MDM4, and p53^{ΔP} was degraded very efficiently in the absence of MDM4 (REF. 40). These data are not consistent with the model that proposes mutual dependence between MDM2 and MDM4 for the control of p53 and MDM2 stability and function⁷⁵. These studies also showed that MDM2 can affect the cell-cycle arrest function of p53, which is not consistent with the model that proposes that MDM2 only regulates apoptosis⁶⁹. Importantly, however, although decreasing levels of MDM2 increased p53^{ΔP} levels as expected, the activity of p53^{ΔP}, on a per molecule basis, was similar in *Mdm2*^{+/+} and *Mdm2*^{+/-} genetic contexts. By contrast,

Table 2 | **Amplification of MDM2, and amplification or overexpression of MDM4 in human tumours**

Tumour type	Percentage of tumours with MDM2 amplification (total number of samples)*	Percentage of tumours with MDM4 amplification (total number of samples)	Percentage of tumours that overexpress MDM4 (total number of samples)	World-wide incidence of new cancer cases per year (estimated cases with MDM2 and/or MDM4 alterations)†
Brain/nervous system**	10.4 (836) (REFS 7,91, 114–116,118, 120–122)	4.6–11.5 [§] (305) (REFS 91,115,117, 119)		189,485 (21,790–41,500)
Breast	5.9 (1804) (REFS 7,123)	4.9–40.1 [§] (162) (REF. 60)	18.8 (218) (REF. 60)	1,151,298 (216,440–284,370)
Genital system				
Uterus	5 (100) (REFS 7,124)		15.4 (13) (REF. 60)	692,026 (106,570–141,170)
Ovary	3.2 (190) (REF. 7)			204,499 (6,540)
Testes	4.6 (65) (REF. 7)		27.3 (11) (REF. 60)	48,613 (13,270–15,510)
Prostate	0 (29) (REF. 125)		0 (25) (REF. 60)	679,023 (0)
Oral cavity / pharynx				
Nasopharynx	2.2 (46) (REF. 7)			80,043 (1,760)
Salivary glands	21.4 (14) (REFS 122,126–128)			nl ca. 51,600 [¶] (11,040)
Digestive system				
Oesophagus	9.1 (187) (REFS 7,129–131)			462,117 (42,050)
Liver (HCC)	44.4 (9) (REF. 132)			ca. 600,000 [#] (266,400)
Liver (Hepatoblastomas)	0 (38) (REF. 7)			nl (0)
Pancreas	0 (27) (REFS 7,126)			232,306 (0)
Stomach/small intestine	32.7 (55) (REFS 122,133)		42.9 (14) (REF. 60)	933,937 (400,660–706,050)
Colon/rectum	0 (44) (REF. 134)		18.5 (27) (REF. 60)	1,023,152 (189,280)
Urinary system				
Bladder	4.9 (1577) (REFS 7,135)			356,557 (17,470)
Kidney	0 (40) (REF. 7)			208,480 (0)**
Respiratory system				
Larynx			23.1 (13) (REF. 60)	159,241 (36,780)
Lung	14.7 (367) (REFS 7,131,136,137)		18.2 (88) (REF. 60)	1,352,132 (246,090–444,850)
Bones	20 (479) (REFS 7,138–148)			nl ca. 30,000 ^{††} (6,000)
Soft Tissue Tumours ^{§§}	30.9 (1065) (REFS 7,122,126, 139,146,148,150-158)	16.7 (66) REF. 149		nl ca. 100,000 ^{††} (30,900–47,600)
Thyroid	0 (22) (REF. 7)			141,013 (0)
Blood				
Leukaemias/Non-Hodgkin lymphomas	0.2 (558) (REFS 7,159–162)			601,093 (1,200)
Hodgkin disease	66.7 (6) (REF. 163)			62,329 (41,510)
Malignant melanoma	2 (153) (REFS 164,165)		14.3 (14) (REF. 60)	160,177 (22,900–26,110)
Total	10.5 (7711)	9.9–24.6 [§] (533)	17.2 (443)	ca 9,500,000 (1,678,650–2,327,190)†

The table lists the frequencies observed, per tumour site, of MDM2 amplification, or MDM4 amplification or overexpression in human tumours. The values were then compared to global cancer statistics to estimate the number of new cancer cases each year presenting such alterations. *Owing to space limitations, all studies previously referenced in the MDM2 gene amplification database by Momand *et al.* are referenced here as REF. 7. †Smaller values represent estimates that consider alterations of MDM2 or MDM4 not to be mutually exclusive, whereas higher values are estimates that consider that they are. As discussed in the text, real values probably lie within these estimates. Global statistics are from REF. 166. **Includes astrocytomas, oligodendriomas, glioblastomas and gliosarcomas (MDM2 and MDM4), and medulloblastomas, ependymomas and neuroblastomas (MDM2). †The smaller value reports cases of high levels of amplification, the higher value reports cases with potentially low levels of amplification. †Based on overexpression analyses from the same study, the highest value seems to be an overestimate, and is not considered in the calculation of the number cancer cases per year, for which overexpression values were used. †As it is not listed as a category in global statistics, the value was calculated by taking into account three other known values: the number of oral cavity and pharynx cancers in the world; the number of identical cancers in the United States, and the number of salivary gland tumours in the United States (according to the American Cancer Society website). †Statistics for all liver cancers are 626,162 new cases per year in the world¹⁶⁶, with about 95% being hepatocellular carcinomas (HCC). The three other types of liver cancer (including hepatoblastomas) are very rare. **Based on a study limited to Wilms tumours. ††Value estimated from known United States statistics. ††Includes leiomyomas/leiomyosarcomas, lipomas/liposarcomas, malignant fibrous histiocytomas and fibrosarcomas (MDM2 and MDM4), and malignant schwannomas (MDM2). nl, not listed as a category in global statistics¹⁶⁶.

MDM4 loss increased p53^{AP} transactivation capacity significantly, and partially restored cell-cycle control without increasing p53^{AP} levels⁴⁰. Importantly, similar observations were made in an elegant study in which wild-type p53 was conditionally activated in mice deficient in either MDM2 or MDM4 (REF. 77). Another study indicated that MDM2 and MDM4 had independent but cooperative roles in the inhibition of p53 in the developing CNS⁷⁸. Together, these studies support the proposal that the important function of MDM2 is to control p53 levels, whereas MDM4 contributes significantly to regulating p53 activity^{40,77}.

It might seem paradoxical that decreasing MDM2 levels stabilized but did not increase p53^{AP} activity (per molecule), as MDM2 mediates p53 degradation and can inhibit p53 activity by TAD occlusion (FIG. 1). However, recent reports help resolve this problem. A crucial step in DNA-damage-mediated p53 activation involves both MDM2 auto-degradation and MDM2-dependent degradation of MDM4 (REFS 79,80). Data from the p53^{AP} mouse model shows that sufficient MDM4 needs to be degraded to enable full p53 activation⁴⁰, and *in vitro* analyses support this conclusion^{81–84}. Presumably, although decreasing MDM2 abundance would make less available for binding to the p53 TAD, MDM4 would also be degraded less efficiently, resulting in more MDM4 being present to antagonize p53 activation. Consistent with the idea that MDM2 is a less efficient transcriptional antagonist than MDM4, we note that massive MDM2 overexpression is required to rescue *Mdm4*^{-/-} embryos⁸⁵. The new model for p53 regulation, that integrates the distinct and complementary roles of MDM2 and MDM4 in p53 inhibition, and the role of MDM2-mediated MDM4 degradation for p53 activation, is summarized in FIG. 4. Importantly, this model might explain the differences in survival of MDM2-deficient and MDM4-deficient embryos in a p53^{AP} context (see detailed discussion in REF. 40). Similarly, the model is consistent with the observed differences in timing and death of MDM2-null and MDM4-null embryos in a wild-type p53 context.

The importance of MDM2 and MDM4 antagonists

In many tumours that express wild-type p53, the function of p53 can be compromised by viral oncogenes such as the papillomavirus E6 and adenovirus E1B proteins that induce p53 degradation^{86,87}. Similarly, MDM2, which also degrades p53, is clearly a clinically relevant cellular oncogene: within 5 years of its discovery as an amplified gene in a transformed murine cell line, it was found to be amplified in 7.2% of 3,889 human tumours that lacked p53 mutations⁷. MDM2 amplification was more recently reported in ~10.5% of 7,711 tumours (TABLE 2 and see [Supplementary information S1](#) (table)) As MDM2 levels are also affected by p53 function, it remains difficult to estimate accurately the fraction of tumours that overexpress MDM2 without *MDM2* gene amplification⁷. However, a recent analysis of a single nucleotide polymorphism (SNP) in the MDM2 promoter showed that a twofold–threefold increased expression of MDM2 is sufficient to reduce p53

function, decrease tumour latency and confer a worse prognosis⁸⁸. Therefore, development of therapeutics that activate p53 by disrupting MDM2–p53 interactions could affect a substantial number of patients given the significant number of tumours with MDM2 amplification and overexpression. Several approaches have shown that antibodies and small molecules that bind MDM2 in its p53-binding pocket might stabilize p53 and induce a p53 response (see REF. 89 and references therein). Among such molecules, Nutlins seem to be very promising: they inhibit xenograft tumour growth with no reported side effects in normal tissues in mice⁸⁹. Because mouse studies show that deleting MDM2 in cells that express wild-type p53 induces cell death without exposure to additional stressors⁷⁴, one might wonder why agents such as Nutlins do not cause considerable collateral damage by killing normal cells. One report recently suggested an explanation: Nutlins might specifically target cancer cells owing to altered signalling pathways in such cells⁹⁰. It is also possible that, unlike the genetic modelling of an MDM2 deficiency in the mouse, Nutlins only partially activate p53 because of a finite dissociation constant from their target and their limited access to cells in the animal.

Is MDM4 also an important oncogene? Several lines of evidence show that it is. MDM4 was found amplified in 9.9% of 533 tumours, and overexpressed in 17.2% of 443 tumours (TABLE 2). This might be an underestimate owing to the relatively limited analysis of MDM4 since its discovery (that is, 80 research articles on MDM4 versus 2,500 papers on MDM2). MDM4 overexpression is functionally relevant as it can prevent p53-mediated tumour suppression⁶⁰. Interestingly, one report suggests that high levels of *MDM2* or *MDM4* gene amplification are mutually exclusive, whereas low levels of amplification of both genes can coexist in a tumour cell⁹¹. This is consistent with the notion that low levels of both oncogenes could produce the same effect as high levels of either alone to suppress p53 function. We suggest that tumours in which array comparative genomic hybridization or other quantitative methods of chromosome analysis show gains of chromosome 12q14.3–q15 (which contains MDM2) and/or 1q32 (which contains MDM4) should be further analysed to determine MDM2 and MDM4 amplification.

Independent evidence for the importance of *MDM4* as an oncogene is provided by an analysis of tumour xenografts in p53^{AP} mice⁴⁰. p53^{AP} suppressed oncogene-induced tumours poorly, and reducing the gene dosage for either *MDM2* or *MDM4* increased its efficiency slightly. However, decreasing the gene dosage for both *MDM2* and *MDM4*, or complete ablation of *MDM4*, made p53^{AP} a potent tumour suppressor⁴⁰. This indicated the importance of MDM4 as a therapeutic target, and that MDM2 and MDM4 antagonists could cooperate to ensure robust p53 activation. Furthermore, recent studies show that although the p53-binding domains of MDM2 and MDM4 are similar, Nutlin3a efficiently antagonizes MDM2–p53 interactions, but not MDM4–p53 interactions^{92–94}. Therefore, Nutlin3a is similar to the peptide MDM2 antagonists analysed

Table 3 | **Proteins that interact with p53 and/or MDM2 and/or MDM4**

Modifications and/or other interactions	p53 + MDM2 + MDM4	p53 + MDM2	p53 + MDM4	MDM2 + MDM4	p53	MDM2	MDM4
Phosphorylation	ATM, CHK2	CK1, CDK2, DNAPK, ERK2, AKT, ABL	CHK1	CDK1	CDK5,7, MAT1, GSK3β, JNK1/2/3, p38 MAPK, PKCα, PKR, MST1, VRK1, ATR, PLK3, HIPK1/2, CK2, ERK1, AURK, CSN5/JAB1, IKKα, LATS2, SMG1, MAPKAPK2		
Dephosphorylation		PP2AC			CDC14		
Ubiquitylation	MDM2	TSG101			PIRH2, COP1, ARF-BP1 (Mule), BIRC6, E4F1, UBE2A, PARC/CUL7, E2-25K	PRAJA1, MTBP	
De-ubiquitylation	HAUSP	DAXX					
Neddylation					NEDD8/45		
Sumoylation		PIAS1, SUMO1			PIASy, Topors	PIASxβ, RANBP2	
Methylation					SET9, SMYD2, CARM1, PRMT1		
Isomerisation					PIN1		
Other signalling pathways		PTEN	14-3-3β, γ, ε, σ, τ, ζ		S100B		14-3-3 η
Chaperones		HSP90A			Hsp70-1, Mortalin 2		
Activators, co-activators	p53, p73, p300	YY1, ZBP89, PML, PCAF	p63, E2F1		SP1, E2F2/3, TFDP1, CBP, YB1, Securin, p29 ING4, p28 ING5, AP2α/γ, AMF1, DDX5, Mucin 1, TRAP220, ADA3, ANKRD2, KLF4/5/6		SMAD3, SMAD4
Repressors, co-repressors		HDAC1			Sin3A, MTA1/2, IFI16, SIRT1, MSX-1, WT1, ATF-3, Huntingtin		
Transcription machinery		TFIID			CCAAT-binding factor, DNA topo I/IIα, RNA pol II EF, TAF9, SMN1, TAF1A/C, TAF3C		
DNA repair, recombination, chromatin remodelling					RAD51, 53BP1, BRCA1/2, BARD1, MDC1, HMG1, BLM, WRN, MRE11, RPA1, ERCC6, SNF5, DNA pol α, mtDNA poly	Histone H4	
Cell-cycle regulation	MDM4, pRB, p19 ^{ARF}	Cyclin G1, gankyrin			Cables, Prohibitin, Ribonucleotide reductase, Nucleostemin, pVHL, p33ING1, SMAR1	pRB-like p107/p130, EID1	
Apoptosis					BAX, BNIP3L, BCL-X _L , ASPP1/2, IASPP, Scotin		Caspase 3
Redox		HIF1α			WOX1, COX2, REF1, Thioredoxin, NQO1		
Nuclear receptors		ERα, GCCR				AR	
Metabolism		Seladin-1, Ribosomal proteins L5/L11			Nucleolin		
Structural					Vimentin	Merlin	

The table was compiled from data listed in the [Human Protein Reference Database](#), the [Biomolecular Interaction Network Database](#) and studies cited in the text. Some transcriptional activators might also function as repressors, and some proteins involved in cell-cycle control might also regulate apoptosis: in all cases, such proteins were listed in only one category. Note that most of the interactions were identified *in vitro* or using transfection procedures: attempts to detect interactions at endogenous protein levels were often not reported. 53BP1, p53 binding protein 1; ADA3, transcriptional adaptor 3-like; AMF1, activation-domain modulating factor 1; AR, androgen receptor; ARF-BP1, p19ARF binding protein 1; ATF3, activating transcription factor 3; ATM, ataxia telangectasia mutated; ANKRD2, Ankyrin repeat domain 2; ATR, ataxia telangectasia and Rad3-related protein; AURK, Aurora kinase A; BARD1, BRCA1-associated RING-domain 1; BIRC6, Baculoviral inhibitor of apoptosis repeat containing 6; BLM, Bloom syndrome helicase; BNIP3L, BCL2/Adenovirus E1B-19K interacting protein 3-like; CARM1, co-activator-associated arginine methyltransferase 1; CBP, CREB-binding protein; CDK, cyclin-dependent kinase; CHK, checkpoint kinase; CK, casein kinase; COX2, cyclooxygenase 2; DDX5, DEAD box protein 5; DNAPK, DNA-dependent protein kinase; CSN5, COP9 signalosome subunit 5; EID1, E1A-like inhibitor of differentiation 1; ERα, oestrogen receptor-α; ERK, extracellular signal-regulated kinase; GCCR, glucocorticoid receptor; GSK3β, glycogen synthase kinase 3β; HAUSP, herpes virus-associated ubiquitin-specific protease; HDAC1, histone deacetylase 1; HIF1α, hypoxia-inducible factor 1α; HIPK, homeodomain-interacting protein kinase; HMG1, high mobility group 1 protein; HSP, heat-shock protein; (i)ASPP, (inhibitor of) apoptosis-stimulating protein of p53; IFI16, interferon-γ-inducible protein; IKK, IκB kinase; ING, inhibitor of growth; JNK, c-Jun NH₂-terminal kinase; KLF, Krüppel-like factor; LATS2, *Drosophila* Large tumour suppressor 2 homolog; MAPKAPK2, mitogen-activated protein kinase-activated protein kinase 2; MDC1, mediator of DNA damage checkpoint protein 1; MST1, macrophage stimulating 1; MSX1, *Drosophila* muscle segment homeobox 1 homolog; MTBP, MDM two binding protein; NQO1, NAD(P)H:quinone oxidoreductase 1; PARC/CUL7, homo- and heterodimers of Parkin-like cytoplasmic protein and Cullin 7; PCAF, p300/CBP associated factor; PKC, protein kinase C; PKR, double stranded RNA-activated kinase; PIAS, protein inhibitor of activated STAT; PIN1, Peptidyl-prolyl cis/trans isomerase NIMA-interacting 1; PIRH2, p53-induced protein with RING-H2 domain; PLK3, pol-like kinase 3; PML, promyelocytic leukaemia; PP2AC, protein phosphatase 2 A subunit C; PRMT1, protein-arginine N-methyl transferase 1; PTEN, phosphatase and tensin homologue deleted on chromosome ten; RANBP2, Ran-binding protein 2; REF1, redox factor 1; RPA1, replication protein 1; RSK2, ribosomal S6 kinase 2; SET9, SET9 methyltransferase; SMN1, survival of motor neuron 1; SMYD2, SET/MYND domain-containing methyltransferase 2; SRT1, sirtuin 1; SUMO, small ubiquitin-like modifier 1; TAF, TATA-binding protein-associated factor; TF-DP1, transcription factor E2F dimerization partner 1; Topors, Topoisomerase I-binding arginine-serine rich protein; TRAP, thyroid hormone receptor-associated protein; UBE2A, ubiquitin conjugating enzyme E2A; pVHL, von Hippel-Lindau protein; VRK1, vaccinia-related kinase 1; WOX1, WW domain-containing oxidoreductase 1; WRN, Werner syndrome helicase; YB1, Y-box binding protein 1; ZBP89, Zinc binding protein 89.

previously⁹⁵. Interestingly, in normal cells and some tumour cell lines, Nutlin3a promotes p53 stabilization, increases p53 levels and activation of MDM2 and the corresponding degradation of MDM4. This leads to a positive-feedback loop for p53 activation^{92,93} (FIG. 4). Importantly however, some tumour cell lines overexpress MDM4 and are resistant to Nutlins^{93,94}, but the combined use of Nutlins with MDM4 small interferingRNAs in cells that overexpress MDM4 can induce apoptosis^{92–94}. These data justify the search for efficient MDM4 antagonists^{40,92–94}, and suggest that they could induce more effective cell killing if used in conjunction with MDM2 antagonists^{92–94}.

The number of human cancers that could be treated by such drugs remains to be determined. Extrapolating from data based on 9,500,000 new cases each year, we estimate about 2,000,000 new cancers each year could have increased expression levels of MDM2 or MDM4, including a significant fraction of lung, breast, colon, stomach, uterus and liver tumours (TABLE 2). Some p53 mutants that retain partial function might also be activated by such drugs, as exemplified by studies with the p53^{ΔP} mouse⁴⁰. According to transactivation assays in yeast, 24% of all p53 missense mutants have decreased, but measurable, p53 activity⁹⁶. These mutants would represent about 1,000,000 cancers diagnosed each year. Therefore, MDM2 and MDM4 antagonists could be used to treat 2,000,000–3,000,000 new cancers each year, and so might be the main drugs of tomorrow, assuming that their therapeutic index is acceptable.

Regulators of p53, MDM2 and MDM4

Although this Review has focused on p53, MDM2 and MDM4, it is important to consider all the proteins that interact with, and therefore might regulate, the activity or stability of these three proteins. TABLE 3 presents the proteins that were found to interact with p53 and/or MDM2 and/or MDM4. It is beyond this Review to detail all these interactions, but a few points are discussed below. First, more proteins seem to interact with p53 than with MDM2 or MDM4, but this might only reflect the larger number of studies that focused on p53. Second, like p53, MDM2 and MDM4 are subject to stress-dependent modifications, such as phosphorylation and ubiquitylation. This might explain, in part, the limited phenotypic effects that are observed after specific residues of mouse p53 were mutated *in vivo*,

as only one of the three members of the p53–MDM2–MDM4 network was affected by the mutations. Third, the model in FIG. 4 postulates the existence of a switch that makes MDM2 preferentially target p53 for degradation in unstressed cells, but target itself and MDM4 in stressed cells. Although the mechanisms that underlie this switch are still being defined, they seem to involve a regulated deubiquitylation of p53, MDM2 and MDM4 by the ubiquitin-protease HAUSP⁸³, and the regulation of HAUSP binding by the adaptor protein DAXX⁹⁷. Therefore, HAUSP and DAXX might also represent promising therapeutic targets. Fourth, it is important to note that most interactions listed in TABLE 3 come from *in vitro* or transfection studies, and it will be crucial to verify their relevance *in vivo*, or at least by targeted mutations in fibroblasts. This is essential, as transfection studies had predicted that HAUSP inhibition would destabilize p53, but the disruption of the *HAUSP* gene in human cells had the opposite effect, because MDM2 stability was primarily affected⁹⁸. Therefore, a better understanding of the specific role for all proteins listed in TABLE 3 requires the use of targeted mutations.

Conclusion

Here we Reviewed recent *in vivo* data that are changing our views about p53 regulation. These studies point to the importance of MDM4 as a p53 regulator and a therapeutic target. Future *in vivo* analyses will be crucial to evaluate the importance of other proposed p53 regulators, such as PIRH2, COP1 and ARF–BP1 (REFS 99–101) (TABLE 3). In addition, the analysis of p53 mutants should increasingly rely on targeted mutations at the mouse *Trp53* locus, rather than transfection procedures. However, targeting p53 mutations to perform *in vivo* analyses is time-consuming and expensive. To accelerate the pace at which targeted mutations can be analysed, and minimize costs, we recently designed a Cre/Lox-based strategy that enabled the efficient targeting of genomic mutations at the *Trp53* locus in both ES cells and fibroblasts¹⁰². The use of this approach at the *Trp53* locus, and its future implementation at *Mdm2* and *Mdm4* loci, should facilitate our understanding of p53 regulation. Importantly, the increased understanding of p53 regulation made available by these studies will provide a new generation of therapeutic agents to awaken the sleeping guardian within a substantial fraction of human cancers.

- Harms, K., Nozell, S. & Chen, X. The common and distinct target genes of the p53 family transcription factors. *Cell. Mol. Life Sci.* **61**, 822–842 (2004).
- Green, D. R. & Chipuk, J. E. p53 and metabolism: inside the TIGAR. *Cell* **126**, 30–32 (2006).
- Mihara, M. *et al.* p53 has a direct apoptogenic role at the mitochondria. *Mol. Cell* **11**, 577–590 (2003).
- Chipuk, J. E., Bouchier-Hayes, L., Kuwana, T., Newmeyer, D. D. & Green, D. R. PUMA couples the nuclear and cytoplasmic proapoptotic function of p53. *Science* **309**, 1732–1735 (2005).
- Ito, A. *et al.* p300/CBP-mediated p53 acetylation is commonly induced by p53-activating agents and inhibited by MDM2. *EMBO J.* **20**, 1331–1340 (2001).
- Vousden, K. H. & Lu, X. Live or let die: the cell's response to p53. *Nature Rev. Cancer* **2**, 594–604 (2002).
- Momand, J., Jung, D., Wilczynski, S. & Niland, J. The *MDM2* gene amplification database. *Nucleic Acids Res.* **26**, 3453–3459 (1998).
- Ashcroft, M., Kubbutat, M. H. & Vousden, K. H. Regulation of p53 function and stability by phosphorylation. *Mol. Cell Biol.* **19**, 1751–1758 (1999).
- Brooks, C. L. & Gu, W. Ubiquitination, phosphorylation and acetylation: the molecular basis for p53 regulation. *Curr. Opin. Cell Biol.* **15**, 164–171 (2003).
- Bode, A. M. & Dong, Z. Post-translational modification of p53 in tumorigenesis. *Nature Rev. Cancer* **4**, 793–805 (2004).
- Ou, Y. H., Chung, P. H., Sun, T. P. & Shieh, S. Y. p53 C-terminal phosphorylation by CHK1 and CHK2 participates in the regulation of DNA-damage-induced C-terminal acetylation. *Mol. Biol. Cell* **16**, 1684–1695 (2005).
- Stavridi, E. S., Chehab, N. H., Malikzay, A. & Halazonetis, T. D. Substitutions that compromise the ionizing radiation-induced association of p53 with 14–3–3 proteins also compromise the ability of p53 to induce cell cycle arrest. *Cancer Res.* **61**, 7030–7033 (2001).
- Liu, Q. *et al.* Aurora-A abrogation of p53 DNA binding and transactivation activity by phosphorylation of serine 215. *J. Biol. Chem.* **279**, 52175–52182 (2004).
- Bischof, O. *et al.* The E3 SUMO ligase PIASy is a regulator of cellular senescence and apoptosis. *Mol. Cell* **22**, 783–94 (2006).
- Di Stefano, V., Soddu, S., Sacchi, A. & D'Orazi, G. HIPK2 contributes to PCAF-mediated acetylation and selective transactivation of p21af1 after nonapoptotic DNA damage. *Oncogene* **24**, 5431–5442 (2005).

16. Knights, C. D. *et al.* Distinct p53 acetylation cassettes differentially influence gene-expression patterns and cell fate. *J. Cell Biol.* **173**, 535–544 (2006).
17. LeCam, L. *et al.* E4F1 is an atypical ubiquitin E3-ligase that modulates p53 effector functions independent of degradation. *Cell* (in the press).
18. Sakaguchi, K. *et al.* DNA damage activates p53 through a phosphorylation-acetylation cascade. *Genes Dev.* **12**, 2831–2841 (1998).
19. Chuikov, S. *et al.* Regulation of p53 activity through lysine methylation. *Nature* **432**, 353–360 (2004).
20. Jimenez, G. *et al.* A transactivation-deficient mouse model provides insights into Trp53 regulation and function. *Nature Genet.* **26**, 37–43 (2000).
21. Chao, C. *et al.* p53 transcriptional activity is essential for p53-dependent apoptosis following DNA damage. *EMBO J.* **19**, 4967–4975 (2000).
22. Lin, J., Chen, J., Elenbaas, B. & Levine, A. J. Several hydrophobic amino acids in the p53 amino-terminal domain are required for transcriptional activation, binding to mdm-2 and the adenovirus 5 E1B 55-kD protein. *Genes Dev.* **8**, 1235–1246 (1994).
23. Johnson, T. M., Hammond, E. M., Giaccia, A. & Attardi, L. D. The p53QS transactivation-deficient mutant shows stress-specific apoptotic activity and induces embryonic lethality. *Nature Genet.* **37**, 145–152 (2005).
24. Wahl, G. M. Mouse bites dogma: how mouse models are changing our views of how p53 is regulated *in vivo*. *Cell Death Differ.* **13**, 973–983 (2006).
25. Tang, M., Wahl, G. M. & Nister, M. Explaining the biological activity of transactivation-deficient p53 variants. *Nature Genet.* **38**, 395–396; author reply 396–397 (2006).
26. Chao, C. *et al.* Cell type- and promoter-specific roles of Ser18 phosphorylation in regulating p53 responses. *J. Biol. Chem.* **278**, 41028–41033 (2003).
27. Sluss, H. K., Armata, H., Gallant, J. & Jones, S. N. Phosphorylation of serine 18 regulates distinct p53 functions in mice. *Mol. Cell Biol.* **24**, 976–984 (2004).
28. Wu, Z. *et al.* Mutation of mouse p53 Ser23 and the response to DNA damage. *Mol. Cell Biol.* **22**, 2441–2449 (2002).
29. MacPherson, D. *et al.* Defective apoptosis and B-cell lymphomas in mice with p53 point mutation at Ser 23. *EMBO J.* **23**, 3689–3699 (2004).
30. Chao, C., Herr, D., Chun, J. & Xu, Y. Ser18 and 23 phosphorylation is required for p53-dependent apoptosis and tumor suppression. *EMBO J.* **25**, 2615–2622 (2006).
This article showed that *in vivo*, phosphorylation events at p53 serine 18 and 23 might have synergistic effects that remain, however, more modest than suggested by transfection studies.
31. Gao, Y. *et al.* Interplay of p53 and DNA-repair protein XRCC4 in tumorigenesis, genomic stability and development. *Nature* **404**, 897–900 (2000).
32. Nakamura, S., Roth, J. A. & Mukhopadhyay, T. Multiple lysine mutations in the C-terminal domain of p53 interfere with MDM2-dependent protein degradation and ubiquitination. *Mol. Cell Biol.* **20**, 9391–9398 (2000).
33. Rodriguez, M. S., Desterro, J. M., Lain, S., Lane, D. P. & Hay, R. T. Multiple C-terminal lysine residues target p53 for ubiquitin-proteasome-mediated degradation. *Mol. Cell Biol.* **20**, 8458–8467 (2000).
34. Krummel, K. A., Lee, C. J., Toledo, F. & Wahl, G. M. The C-terminal lysines fine-tune p53 stress responses in a mouse model, but are not required for stability control or transactivation. *Proc. Natl Acad. Sci. USA* **102**, 10188–10193 (2005).
This article showed that *in vivo*, the mutation of the 7 C-terminal lysines of p53 has little phenotypic consequence.
35. Feng, L., Lin, T., Uranishi, H., Gu, W. & Xu, Y. Functional analysis of the roles of posttranslational modifications at the p53 C terminus in regulating p53 stability and activity. *Mol. Cell Biol.* **25**, 5389–5395 (2005).
36. Dumaz, N., Milne, D. M., Jardine, L. J. & Meek, D. W. Critical roles for the serine 20, but not the serine 15, phosphorylation site and for the polyproline domain in regulating p53 turnover. *Biochem J.* **359**, 459–464 (2001).
37. Berger, M., Vogt Sionov, R., Levine, A. J. & Haupt, Y. A role for the polyproline domain of p53 in its regulation by Mdm2. *J. Biol. Chem.* **276**, 3785–3790 (2001).
38. Berger, M., Stahl, N., Del Sal, G. & Haupt, Y. Mutations in proline 82 of p53 impair its activation by Pin1 and Chk2 in response to DNA damage. *Mol. Cell Biol.* **25**, 5380–5388 (2005).
39. Dornan, D., Shimizu, H., Burch, L., Smith, A. J. & Hupp, T. R. The proline repeat domain of p53 binds directly to the transcriptional coactivator p300 and allosterically controls DNA-dependent acetylation of p53. *Mol. Cell Biol.* **23**, 8846–8861 (2003).
40. Toledo, F. *et al.* A mouse p53 mutant lacking the proline rich domain rescues Mdm4 deficiency and provides insight into the Mdm2-Mdm4-p53 regulatory network. *Cancer Cell* **9**, 273–285 (2006).
Together with reference 77, this article showed that MDM2 and MDM4 regulate p53 in distinct ways. In addition, it disclosed MDM4 as a relevant therapeutic target, and indicated that MDM2 and MDM4 inhibitors could cooperate to activate p53.
41. Sakamuro, D., Sabbatini, P., White, E. & Prendergast, G. C. The polyproline region of p53 is required to activate apoptosis but not growth arrest. *Oncogene* **15**, 887–898 (1997).
42. Venot, C. *et al.* The requirement for the p53 proline-rich functional domain for mediation of apoptosis is correlated with specific PIG3 gene transactivation and with transcriptional repression. *EMBO J.* **17**, 4668–4679 (1998).
43. Zhu, J., Jiang, J., Zhou, W., Zhu, K. & Chen, X. Differential regulation of cellular target genes by p53 devoid of the PXP motifs with impaired apoptotic activity. *Oncogene* **18**, 2149–2155 (1999).
44. Roth, J., Koch, P., Contente, A. & Dobbela, M. Tumor-derived mutations within the DNA-binding domain of p53 that phenotypically resemble the deletion of the proline-rich domain. *Oncogene* **19**, 1834–1842 (2000).
45. Baptiste, N., Friedlander, P., Chen, X. & Prives, C. The proline-rich domain of p53 is required for cooperation with anti-neoplastic agents to promote apoptosis of tumor cells. *Oncogene* **21**, 9–21 (2002).
46. Edwards, S. J., Hananea, L., Eccles, M. R., Zhang, Y. F. & Braithwaite, A. W. The proline-rich region of mouse p53 influences transactivation and apoptosis but is largely dispensable for these functions. *Oncogene* **22**, 4517–4523 (2003).
47. Chipuk, J. E. *et al.* Direct activation of Bax by p53 mediates mitochondrial membrane permeabilization and apoptosis. *Science* **303**, 1010–1014 (2004).
48. Kapoor, M. & Lozano, G. Functional activation of p53 via phosphorylation following DNA damage by UV but not gamma radiation. *Proc. Natl Acad. Sci. USA* **95**, 2834–2837 (1998).
49. Lu, H., Taya, Y., Ikeda, M. & Levine, A. J. Ultraviolet radiation, but not gamma radiation or etoposide-induced DNA damage, results in the phosphorylation of the murine p53 protein at serine-389. *Proc. Natl Acad. Sci. USA* **95**, 6399–6402 (1998).
50. Bruins, W. *et al.* Increased sensitivity to UV radiation in mice with a p53 point mutation at Ser389. *Mol. Cell Biol.* **24**, 8884–8894 (2004).
51. Olivier, M. *et al.* The IARC TP53 database: new online mutation analysis and recommendations to users. *Hum. Mutat.* **19**, 607–614 (2002).
52. Kato, S. *et al.* Understanding the function-structure and function-mutation relationships of p53 tumor suppressor protein by high-resolution missense mutation analysis. *Proc. Natl Acad. Sci. USA* **100**, 8424–8429 (2003).
This article has provided a logical explanation for the distribution of p53 mutations in human tumours, which suggests that transactivation is essential for p53 to suppress tumour formation.
53. Olive, K. P. *et al.* Mutant p53 gain of function in two mouse models of Li-Fraumeni syndrome. *Cell* **119**, 847–860 (2004).
This article (and reference 54) showed that mouse p53 mutants of hot-spots frequently found in human tumours acquire oncogenic properties.
54. Lang, G. A. *et al.* Gain of function of a p53 hot spot mutation in a mouse model of Li-Fraumeni syndrome. *Cell* **119**, 861–872 (2004).
55. Hingorani, S. R. *et al.* Trp53R172H and KrasG12D cooperate to promote chromosomal instability and widely metastatic pancreatic ductal adenocarcinoma in mice. *Cancer Cell* **7**, 469–483 (2005).
56. Liu, G. *et al.* Chromosome stability, in the absence of apoptosis, is critical for suppression of tumorigenesis in Trp53 mutant mice. *Nature Genet.* **36**, 63–68 (2004).
57. Kakudo, Y., Shibata, H., Otsuka, K., Kato, S. & Ishioka, C. Lack of correlation between p53-dependent transcriptional activity and the ability to induce apoptosis among 179 mutant p53s. *Cancer Res.* **65**, 2108–2114 (2005).
58. Renzing, J. & Lane, D. P. p53-dependent growth arrest following calcium phosphate-mediated transfection of murine fibroblasts. *Oncogene* **10**, 1865–1868 (1995).
59. Landers, J. E., Cassel, S. L. & George, D. L. Translational enhancement of mdm2 oncogene expression in human tumor cells containing a stabilized wild-type p53 protein. *Cancer Res.* **57**, 3562–3568 (1997).
60. Danovi, D. *et al.* Amplification of Mdmx (or Mdm4) directly contributes to tumor formation by inhibiting p53 tumor suppressor activity. *Mol. Cell Biol.* **24**, 5835–5843 (2004).
Although MDM4 amplification was shown before in a subset of gliomas (reference 117), this article is the first to document the frequent overexpression of MDM4 in many different cancer sites.
61. Bourdon, J. C. *et al.* p53 isoforms can regulate p53 transcriptional activity. *Genes Dev.* **19**, 2122–2137 (2005).
This article shows the previously unsuspected existence of several p53 isoforms, and suggests their relevance to p53 tumour suppression.
62. Strahl, B. D. & Allis, C. D. The language of covalent histone modifications. *Nature* **403**, 41–45 (2000).
63. Jones, S. N., Roe, A. E., Donehower, L. A. & Bradley, A. Rescue of embryonic lethality in Mdm2-deficient mice by absence of p53. *Nature* **378**, 206–208 (1995).
64. Montes de Oca Luna, R., Wagner, D. S. & Lozano, G. Rescue of early embryonic lethality in mdm2-deficient mice by deletion of p53. *Nature* **378**, 203–206 (1995).
65. Shvarts, A. *et al.* MDMX: a novel p53-binding protein with some functional properties of MDM2. *EMBO J.* **15**, 5349–5357 (1996).
66. Jackson, M. W. & Berberich, S. J. MdmX protects p53 from Mdm2-mediated degradation. *Mol. Cell Biol.* **20**, 1001–1007 (2000).
67. Marine, J. C. & Jochemsen, A. G. Mdmx as an essential regulator of p53 activity. *Biochem. Biophys. Res. Commun.* **331**, 750–760 (2005).
68. Stad, R. *et al.* Hdmx stabilizes Mdm2 and p53. *J. Biol. Chem.* **275**, 28039–28044 (2000).
69. Parant, J. *et al.* Rescue of embryonic lethality in Mdm4-null mice by loss of Trp53 suggests a nonoverlapping pathway with MDM2 to regulate p53. *Nature Genet.* **29**, 92–95 (2001).
This article (and references 70 and 71) showed that MDM4 is a p53 regulator essential to mouse embryonic development.
70. Migliorini, D. *et al.* Mdm4 (Mdmx) regulates p53-induced growth arrest and neuronal cell death during early embryonic mouse development. *Mol. Cell Biol.* **22**, 5527–5538 (2002).
71. Finch, R. A. *et al.* mdmx is a negative regulator of p53 activity *in vivo*. *Cancer Res.* **62**, 3221–3225 (2002).
72. Chavez-Reyes, A. *et al.* Switching mechanisms of cell death in mdm2- and mdm4-null mice by deletion of p53 downstream targets. *Cancer Res.* **63**, 8664–8669 (2003).
73. Steinman, H. A., Sluss, H. K., Sands, A. T., Pihan, G. & Jones, S. N. Absence of p21 partially rescues Mdm4 loss and uncovers an antiproliferative effect of Mdm4 on cell growth. *Oncogene* **23**, 3035–3046 (2004).
74. Marine, J. C. *et al.* Keeping p53 in check: essential and synergistic functions of Mdm2 and Mdm4. *Cell Death Differ.* **13**, 927–934 (2006).
75. Gu, J. *et al.* Mutual dependence of MDM2 and MDMX in their functional inactivation of p53. *J. Biol. Chem.* **277**, 19251–19254 (2002).
76. Linares, L. K., Hengstermann, A., Ciechanover, A., Muller, S. & Scheffner, M. HdmX stimulates Mdm2-mediated ubiquitination and degradation of p53. *Proc. Natl Acad. Sci. USA* **100**, 12009–12014 (2003).
77. Francoz, S. *et al.* Mdm4 and Mdm2 cooperate to inhibit p53 activity in proliferating and quiescent cells *in vivo*. *Proc. Natl Acad. Sci. USA* **103**, 3232–3237 (2006).
This article (and reference 40) showed that MDM2 and MDM4 regulate p53 in distinct and complementary ways.
78. Xiong, S., Van Pelt, C. S., Elizondo-Fraire, A. C., Liu, G. & Lozano, G. Synergistic roles of Mdm2 and Mdm4 for p53 inhibition in central nervous system development. *Proc. Natl Acad. Sci. USA* **103**, 3226–3231 (2006).
79. Kawai, H. *et al.* DNA damage-induced MDMX degradation is mediated by MDM2. *J. Biol. Chem.* **278**, 45946–45953 (2003).
This article showed the MDM2-dependent degradation of MDM4 after DNA damage.
80. Stommel, J. M. & Wahl, G. M. Accelerated MDM2 auto-degradation induced by DNA-damage kinases is required for p53 activation. *EMBO J.* **23**, 1547–1556 (2004).
This article showed that after DNA damage, MDM2 self-destruction is important to induce a p53 response.

81. Chen, L., Gilkes, D. M., Pan, Y., Lane, W. S. & Chen, J. ATM and Chk2-dependent phosphorylation of MDMX contribute to p53 activation after DNA damage. *EMBO J.* **24**, 3411–3422 (2005).
82. Pereg, Y. *et al.* Phosphorylation of Hdmx mediates its Hdm2- and ATM-dependent degradation in response to DNA damage. *Proc. Natl Acad. Sci. USA* **102**, 5056–5061 (2005).
83. Meulmeester, E. *et al.* Loss of HAUSP-mediated deubiquitination contributes to DNA damage-induced destabilization of Hdmx and Hdm2. *Mol. Cell* **18**, 565–576 (2005).
- This article showed that HAUSP regulates the stability of MDM2 and MDM4.**
84. Okamoto, K. *et al.* DNA damage-induced phosphorylation of Mdmx at serine 367 activates p53 by targeting Mdmx for Mdm2-dependent degradation. *Mol. Cell Biol.* **25**, 9608–9620 (2005).
85. Steinman, H. A., Hoover, K. M., Keeler, M. L., Sands, A. T. & Jones, S. N. Rescue of Mdm4-deficient mice by Mdm2 reveals functional overlap of Mdm2 and Mdm4 in development. *Oncogene* **24**, 7935–7940 (2005).
86. Doorbar, J. Molecular biology of human papillomavirus infection and cervical cancer. *Clin. Sci. (Lond.)* **110**, 525–541 (2006).
87. Berk, A. J. Recent lessons in gene expression, cell cycle control, and cell biology from adenovirus. *Oncogene* **24**, 7673–7685 (2005).
88. Bond, G. L. *et al.* A single nucleotide polymorphism in the MDM2 promoter attenuates the p53 tumor suppressor pathway and accelerates tumor formation in humans. *Cell* **119**, 591–602 (2004).
- This article showed that a SNP in the MDM2 promoter can accelerate tumour onset in humans. SNPs in other promoters might also affect p53 regulation.**
89. Vassilev, L. T. *et al.* In vivo activation of the p53 pathway by small-molecule antagonists of MDM2. *Science* **303**, 844–848 (2004).
- This article describes the Nutlins, small molecules that antagonize MDM2–p53 interactions to limit tumour growth.**
90. Brummelkamp, T. R. *et al.* An shRNA barcode screen provides insight into cancer cell vulnerability to MDM2 inhibitors. *Nature Chem. Biol.* **2**, 202–206 (2006).
91. Arjona, D. *et al.* Real-time quantitative PCR analysis of regions involved in gene amplification reveals gene overexpression in low-grade astrocytic gliomas. *Diagn. Mol. Pathol.* **14**, 224–229 (2005).
92. Patton, J. T. *et al.* Levels of HdmX expression dictate the sensitivity of normal and transformed cells to Nutlin-3. *Cancer Res.* **66**, 3169–3176 (2006).
93. Wade, M., Wong, E. T., Tang, M., Vassilev, L. T. & Wahl, G. M. Hdmx modulates the outcome of p53 activation in human tumor cells. *J. Biol. Chem.* (13 August 2006, doi 10.1074/jcb.M605405200).
94. Hu, B., Gilkes, D. M., Farooqi, B., Sebti, S. M. & Chen, J. MDMX overexpression prevents P53 activation by the MDM2 inhibitor nutlin. *J. Biol. Chem.* (11 August 2006, doi 10.1074/jcb.C600147200).
95. Bottger, V. *et al.* Comparative study of the p53-mdm2 and p53-MDMX interfaces. *Oncogene* **18**, 189–199 (1999).
96. Soussi, T., Kato, S., Levy, P. P. & Ishioka, C. Reassessment of the TP53 mutation database in human disease by data mining with a library of TP53 missense mutations. *Hum. Mutat.* **25**, 6–17 (2005).
97. Tang, J. *et al.* Critical role for Daxx in regulating Mdm2. *Nature Cell Biol.* **8**, 855–862 (2006).
- This article disclosed Daxx as an adaptor protein that would direct HAUSP to its targets.**
98. Cummins, J. M. *et al.* Tumour suppression: disruption of HAUSP gene stabilizes p53. *Nature* **428**, 1 p following 486 (2004).
- This article showed that the targeted disruption of the HAUSP gene in human fibroblasts unexpectedly stabilizes p53, which suggested that MDM2 could also be regulated by HAUSP.**
99. Leng, R. P. *et al.* Pirh2, a p53-induced ubiquitin-protein ligase, promotes p53 degradation. *Cell* **112**, 779–791 (2003).
100. Dornan, D. *et al.* The ubiquitin ligase COP1 is a critical negative regulator of p53. *Nature* **429**, 86–92 (2004).
101. Chen, D. *et al.* ARF-BP1/Mule is a critical mediator of the ARF tumor suppressor. *Cell* **121**, 1071–1083 (2005).
102. Toledo, F., Liu, C. W., Lee, C. J. & Wahl, G. M. RMCE-ASAP: a gene targeting method for ES and somatic cells to accelerate phenotype analyses. *Nucleic Acids Res.* **34**, e92 (2006).
103. Walker, K. & Levine, A. Identification of a novel p53 functional domain that is necessary for efficient growth suppression. *Proc. Natl. Acad. Sci. USA* **93**, 15335–15340 (1996).
104. Chang, J., Kim, D. H., Lee, S. W., Choi, K. Y. & Sung, Y. C. Transactivation ability of p53 transcriptional activation domain is directly related to the binding affinity to TATA-binding protein. *J. Biol. Chem.* **270**, 25014–25019 (1995).
105. McKinney, K., Mattia, M., Gottifredi, V. & Prives, C. p53 linear diffusion along DNA requires its C terminus. *Mol. Cell* **16**, 413–424 (2004).
106. Weinberg, R. L., Freund, S. M., Vepintsev, D. B., Bycroft, M. & Fersht, A. R. Regulation of DNA binding of p53 by its C-terminal domain. *J. Mol. Biol.* **342**, 801–811 (2004).
107. Stommel, J. M. *et al.* A leucine-rich nuclear export signal in the p53 tetramerization domain: regulation of subcellular localization and p53 activity by NES masking. *EMBO J.* **18**, 1660–1672 (1999).
108. Oliner, J. D. *et al.* Oncoprotein MDM2 conceals the activation domain of tumour suppressor p53. *Nature* **362**, 857–860 (1993).
109. Honda, R., Tanaka, H. & Yasuda, H. Oncoprotein MDM2 is a ubiquitin ligase E3 for tumour suppressor p53. *FEBS Lett.* **420**, 25–27 (1997).
110. Craig, A. L. *et al.* Novel phosphorylation sites of human tumour suppressor protein p53 at Ser20 and Thr18 that disrupt the binding of mdm2 (mouse double minute 2) protein are modified in human cancers. *Biochem. J.* **342**, 133–141 (1999).
111. Zhang, Y. & Xiong, Y. A p53 amino-terminal nuclear export signal inhibited by DNA damage-induced phosphorylation. *Science* **292**, 1910–1915 (2001).
112. Lambert, P. F., Kashanchi, F., Radonovich, M. F., Shiekhhattar, R. & Brady, J. N. Phosphorylation of p53 serine 15 increases interaction with CBP. *J. Biol. Chem.* **273**, 33048–33053 (1998).
113. Laptenko, O. & Prives, C. Transcriptional regulation by p53: one protein, many possibilities. *Cell Death Differ.* **13**, 951–961 (2006).
114. Ichimura, K. *et al.* Deregulation of the p14ARF/MDM2/p53 pathway is a prerequisite for human astrocytic gliomas with G1–S transition control gene abnormalities. *Cancer Res.* **60**, 417–424 (2000).
115. Alonso, M. E. *et al.* Real-time quantitative PCR analysis of gene dosages reveals gene amplification in low-grade oligodendrogliomas. *Am. J. Clin. Pathol.* **123**, 900–906 (2005).
116. Bello, M. J. & Rey, J. A. The p53/Mdm2/p14ARF cell cycle control pathway genes may be inactivated by genetic and epigenetic mechanisms in gliomas. *Cancer Genet. Cytogenet.* **164**, 172–173 (2006).
117. Riemenschneider, M. J. *et al.* Amplification and overexpression of the MDM4 (MDMX) gene from 1q32 in a subset of malignant gliomas without TP53 mutation or MDM2 amplification. *Cancer Res.* **59**, 6091–6096 (1999).
118. Actor, B. *et al.* Comprehensive analysis of genomic alterations in gliosarcoma and its two tissue components. *Genes Chromosomes Cancer* **34**, 416–427 (2002).
119. Riemenschneider, M. J., Knobbe, C. B. & Reifenberger, G. Refined mapping of 1q32 amplicons in malignant gliomas confirms MDM4 as the main amplification target. *Int. J. Cancer* **104**, 752–757 (2003).
120. Iwato, M. *et al.* Molecular analysis for p53 and mdm2 in intracranial germ cell tumors. *Acta Neuropathol. (Berl.)* **99**, 21–25 (2000).
121. Herrlinger, U. *et al.* Gliomatosis cerebri: molecular pathology and clinical course. *Ann. Neurol.* **52**, 390–399 (2002).
122. Binh, M. B. *et al.* MDM2 and CDK4 immunostainings are useful adjuncts in diagnosing well-differentiated and dedifferentiated liposarcoma subtypes: a comparative analysis of 559 soft tissue neoplasms with genetic data. *Am. J. Surg. Pathol.* **29**, 1340–1347 (2005).
123. Ho, C. H. *et al.* Genetic alterations of the p14ARF-hdm2-p53 regulatory pathway in breast carcinoma. *Breast Cancer Res. Treat.* **65**, 225–232 (2001).
124. Seki, A. *et al.* Amplification of the mdm-2 gene and p53 abnormalities in uterine sarcomas. *Int. J. Cancer* **73**, 33–37 (1997).
125. Ittmann, M. *et al.* Alterations in the p53 and MDM-2 genes are infrequent in clinically localized, stage B prostate adenocarcinomas. *Am. J. Pathol.* **145**, 287–293 (1994).
126. Gisselsson, D., Mandahl, N., Palsson, E., Gorunova, L. & Hoglund, M. Locus-specific multifluor FISH analysis allows physical characterization of complex chromosome abnormalities in neoplasia. *Genes Chromosomes Cancer* **28**, 347–352 (2000).
127. Jin, C. *et al.* Characterization of chromosome aberrations in salivary gland tumors by FISH, including multicolor COBRA-FISH. *Genes Chromosomes Cancer* **30**, 161–167 (2001).
128. Roijer, E. *et al.* Translocation, deletion/amplification, and expression of HMGC and MDM2 in a carcinoma ex pleomorphic adenoma. *Am. J. Pathol.* **160**, 433–440 (2002).
129. Taniere, P. *et al.* TP53 mutations and MDM2 gene amplification in squamous-cell carcinomas of the esophagus in south Thailand. *Int. J. Cancer* **88**, 223–227 (2000).
130. Ishizuka, T. *et al.* Gene amplification profiling of esophageal squamous cell carcinomas by DNA array CGH. *Biochem Biophys Res Commun* **296**, 152–155 (2002).
131. Miller, C. T. *et al.* Amplification and overexpression of the dual-specificity tyrosine-(Y)-phosphorylation regulated kinase 2 (DYRK2) gene in esophageal and lung adenocarcinomas. *Cancer Res.* **63**, 4136–4143 (2003).
132. Jablkowski, M., Bocian, A., Bialkowska, J. & Bartkowiak, J. A comparative study of P53/MDM2 genes alterations and P53/MDM2 proteins immunoreactivity in liver cirrhosis and hepatocellular carcinoma. *J. Exp. Clin. Cancer Res.* **24**, 117–125 (2005).
133. Gunther, T. *et al.* Mdm2 gene amplification in gastric cancer correlation with expression of Mdm2 protein and p53 alterations. *Mod. Pathol.* **13**, 621–626 (2000).
134. Oliva, M. R. *et al.* Genetic alterations and oxidative metabolism in sporadic colorectal tumors from a Spanish community. *Mol. Carcinog.* **18**, 232–243 (1997).
135. Simon, R. *et al.* Amplification pattern of 12q13-q15 genes (MDM2, CDK4, GLI) in urinary bladder cancer. *Oncogene* **21**, 2476–2483 (2002).
136. Bode-Lesniewska, B. *et al.* Gains of 12q13–14 and overexpression of mdm2 are frequent findings in intimal sarcomas of the pulmonary artery. *Virchows Arch.* **438**, 57–65 (2001).
137. Dworakowska, D. *et al.* MDM2 gene amplification: a new independent factor of adverse prognosis in non-small cell lung cancer (NSCLC). *Lung Cancer* **43**, 285–295 (2004).
138. Yokoyama, R., Schneider-Stock, R., Radig, K., Wex, T. & Roessner, A. Clinicopathologic implications of MDM2, p53 and K-ras gene alterations in osteosarcomas: MDM2 amplification and p53 mutations found in progressive tumors. *Pathol. Res. Pract.* **194**, 615–621 (1998).
139. Gisselsson, D., Hoglund, M., Mertens, F., Mitelman, F. & Mandahl, N. Chromosomal organization of amplified chromosome 12 sequences in mesenchymal tumors detected by fluorescence *in situ* hybridization. *Genes Chromosomes Cancer* **23**, 203–212 (1998).
140. Tarkkanen, M. *et al.* Comparative genomic hybridization of low-grade central osteosarcoma. *Mod. Pathol.* **11**, 421–426 (1998).
141. Ragazzini, P. *et al.* Analysis of SAS gene and CDK4 and MDM2 proteins in low-grade osteosarcoma. *Cancer Detect Prev.* **23**, 129–136 (1999).
142. Wei, G. *et al.* CDK4 gene amplification in osteosarcoma: reciprocal relationship with *INK4A* gene alterations and mapping of 12q13 amplicons. *Int. J. Cancer* **80**, 199–204 (1999).
143. Wunder, J. S. *et al.* Co-amplification and overexpression of CDK4, SAS and MDM2 occurs frequently in human parosteal osteosarcomas. *Oncogene* **18**, 783–788 (1999).
144. Lopes, M. A., Nikitakis, N. G., Ord, R. A. & Sauk, J., Jr. Amplification and protein expression of chromosome 12q13–15 genes in osteosarcomas of the jaws. *Oral Oncol.* **37**, 566–571 (2001).
145. Gisselsson, D. *et al.* Differentially amplified chromosome 12 sequences in low- and high-grade osteosarcoma. *Genes Chromosomes Cancer* **33**, 133–140 (2002).
146. Kawaguchi, K. *et al.* Molecular analysis of p53, MDM2, and H-ras genes in osteosarcoma and malignant fibrous histiocytoma of bone in patients older than 40 years. *Mod. Pathol.* **15**, 878–888 (2002).
147. Man, T. K. *et al.* Genome-wide array comparative genomic hybridization analysis reveals distinct amplifications in osteosarcoma. *BMC Cancer* **4**, 45 (2004).
148. Heidenblad, M. *et al.* Genomic profiling of bone and soft tissue tumors with supernumerary ring chromosomes using tiling resolution bacterial artificial chromosome microarrays. *Oncogene* (2006).
149. Bartel, F. *et al.* Significance of HDMX-S (or MDM4) mRNA splice variant overexpression and HDMX gene amplification on primary soft tissue sarcoma prognosis. *Int. J. Cancer* **117**, 469–475 (2005).
150. Pedeutour, F. *et al.* Structure of the supernumerary ring and giant rod chromosomes in adipose tissue tumors. *Genes Chromosomes Cancer* **24**, 30–41 (1999).

151. Pilotti, S. *et al.* The expression of *MDM2/CDK4* gene product in the differential diagnosis of well differentiated liposarcoma and large deep-seated lipoma. *Br. J. Cancer* **82**, 1271–1275 (2000).
152. Dei Tos, A. P. *et al.* Coordinated expression and amplification of the *MDM2*, *CDK4*, and *HMGIC* genes in atypical lipomatous tumours. *J. Pathol.* **190**, 531–536 (2000).
153. Forus, A. *et al.* Dedifferentiation of a well-differentiated liposarcoma to a highly malignant metastatic osteosarcoma: amplification of 12q14 at all stages and gain of 1q22-q24 associated with metastases. *Cancer Genet. Cytogenet.* **125**, 100–111 (2001).
154. Palmer, J. L., Masui, S., Pritchard, S., Kalousek, D. K. & Sorensen, P. H. Cytogenetic and molecular genetic analysis of a pediatric pleomorphic sarcoma reveals similarities to adult malignant fibrous histiocytoma. *Cancer Genet. Cytogenet.* **95**, 141–147 (1997).
155. Chibon, F. *et al.* The use of clustering software for the classification of comparative genomic hybridization data: an analysis of 109 malignant fibrous histiocytomas. *Cancer Genet. Cytogenet.* **141**, 75–78 (2003).
156. Schmidt, H. *et al.* Gains of 12q are the most frequent genomic imbalances in adult fibrosarcoma and are correlated with a poor outcome. *Genes Chromosomes Cancer* **34**, 69–77 (2002).
157. Bartel, F. *et al.* Amplification of the *MDM2* gene, but not expression of splice variants of *MDM2* mRNA, is associated with prognosis in soft tissue sarcoma. *Int. J. Cancer* **95**, 168–175 (2001).
158. Taubert, H. *et al.* Loss of heterozygosity at 12q14–15 often occurs in stage I soft tissue sarcomas and is associated with *MDM2* amplification in tumors at various stages. *Mod. Pathol.* **16**, 1109–1116 (2003).
159. Preudhomme, C. *et al.* Absence of amplification of *MDM2* gene, a regulator of p53 function, in myelodys-plastic syndromes. *Leukemia* **7**, 1291–1293 (1993).
160. Sugimoto, K. J., Kawamata, N., Sakajiri, S. & Oshimi, K. Molecular analysis of oncogenes, ras family genes (N-ras, K-ras, H-ras), myc family genes (c-myc, N-myc) and *mdm2* in natural killer cell neoplasms. *Jpn J. Cancer Res.* **93**, 1270–1277 (2002).
161. Hernandez, L. *et al.* *CDK4* and *MDM2* gene alterations mainly occur in highly proliferative and aggressive mantle cell lymphomas with wild-type *INK4a/ARF* locus. *Cancer Res.* **65**, 2199–2206 (2005).
162. Wojcik, I. *et al.* Abnormalities of the *P53*, *MDM2*, *BCL2* and *BAX* genes in acute leukemias. *Neoplasma* **52**, 318–324 (2005).
163. Kupper, M. *et al.* *MDM2* gene amplification and lack of p53 point mutations in Hodgkin and Reed-Sternberg cells: results from single-cell polymerase chain reaction and molecular cytogenetic studies. *Br. J. Haematol.* **112**, 768–775 (2001).
164. Polsky, D. *et al.* *HDM2* protein overexpression, but not gene amplification, is related to tumorigenesis of cutaneous melanoma. *Cancer Res.* **61**, 7642–7646 (2001).
165. Muthusamy, V. *et al.* Amplification of *CDK4* and *MDM2* in malignant melanoma. *Genes Chromosomes Cancer* **45**, 447–454 (2006).
166. Parkin, D. M., Bray, F., Ferlay, J. & Pisani, P. Global cancer statistics, 2002. *CA Cancer J. Clin.* **55**, 74–108 (2005).

Acknowledgements

We thank Mark Wade for critical comments on the manuscript. We would like to apologize for the many studies that could not be cited in the present review due to space constraints. Please refer to the review by Bode and Dong (reference 10) for earlier references on p53 post-translational modifications, to the review by Momand *et al.* (reference 7) for early evidence of *MDM2* gene amplification in tumours, and to the BIND and HPRD databases (Table 3) for more references on proteins that interact with p53, *MDM2* and *MDM4*. Also, we acknowledge the functional and clinical importance of the numerous p53 target genes (reviewed in references 1,2), but were unable to discuss them in detail here, again due to space constraints.

Competing interests statement

The authors declare no competing financial interests.

DATABASES

The following terms in this article are linked online to:

Entrez Gene: <http://www.ncbi.nlm.nih.gov/entrez/query.fcgi?db=gene>

Aurora kinase A | BAX | CBP | CDKN1A | CHK2 | E4F1 | MDM2 | MDM4 | p53 | p300 | PCAF | PIN1 | PUMA | RB | SET9 | SMYD2 | XRCC4

FURTHER INFORMATION

Author's homepage: <http://pingu.salk.edu/~wahl>

Human Protein Reference Database: <http://www.hprd.org>

Biomolecular Interaction Network Database:

<http://www.bind.ca>

IARC TP53 Mutation Database: <http://www-p53.iarc.fr>

SUPPLEMENTARY INFORMATION

See online article: S1 (table)

Access to this interactive links box is free online.